

SHOTGUN® GATE CLOSER

www.nationwideindustries.com

INSTALLATION AND ADJUSTMENT INSTRUCTIONS

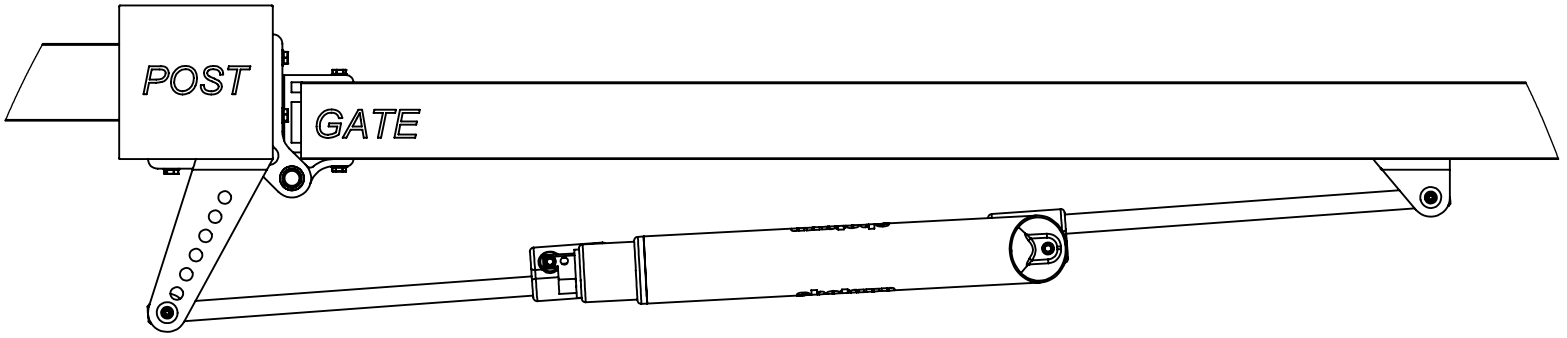
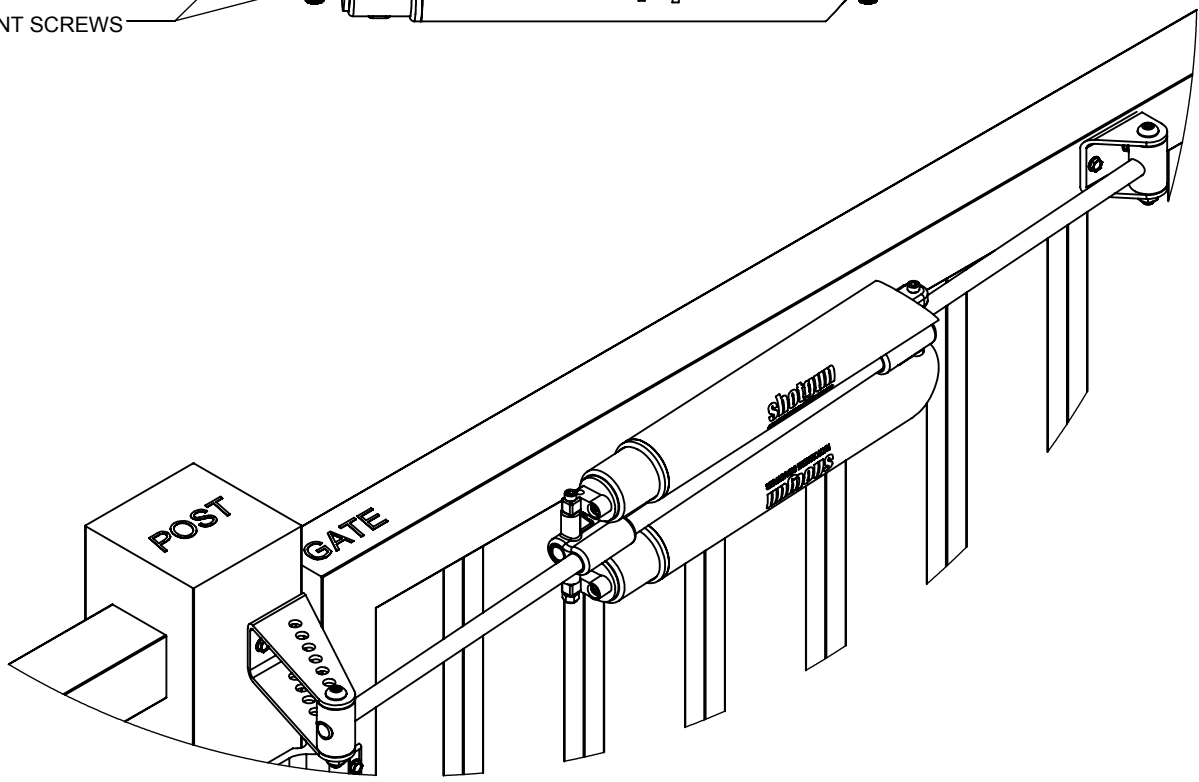
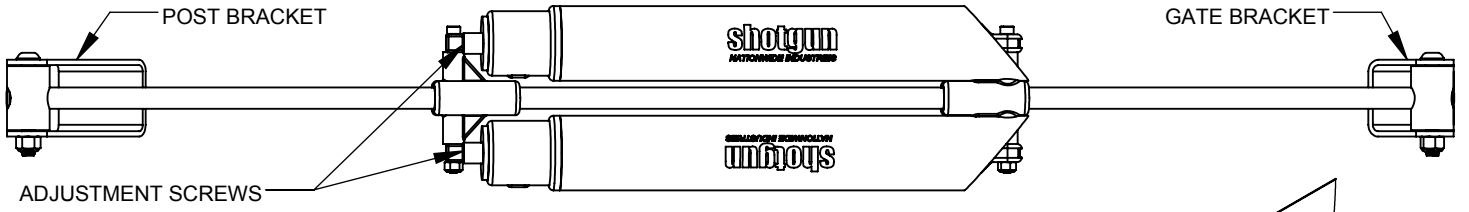
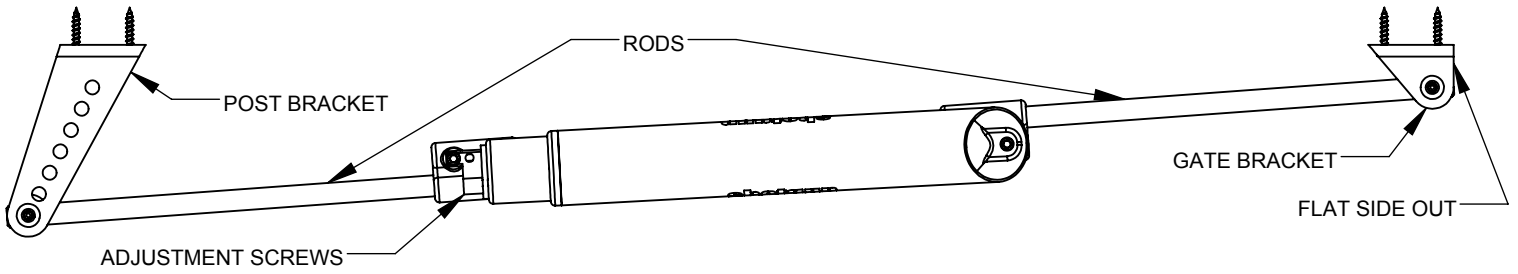

SHOTGUN® GATE CLOSER

www.nationwideindustries.com

INSTALLATION AND ADJUSTMENT INSTRUCTIONS

1A - Check the gate, hinges and latch for problems and make sure all are in good condition and functioning properly. Gate should swing smoothly and easily. Now is a good time to clean, lubricate and level the gate.

1B - Locate the hinge axis or pivot point.

1C - Using a pencil, draw a horizontal line on the post at the desired installation height.

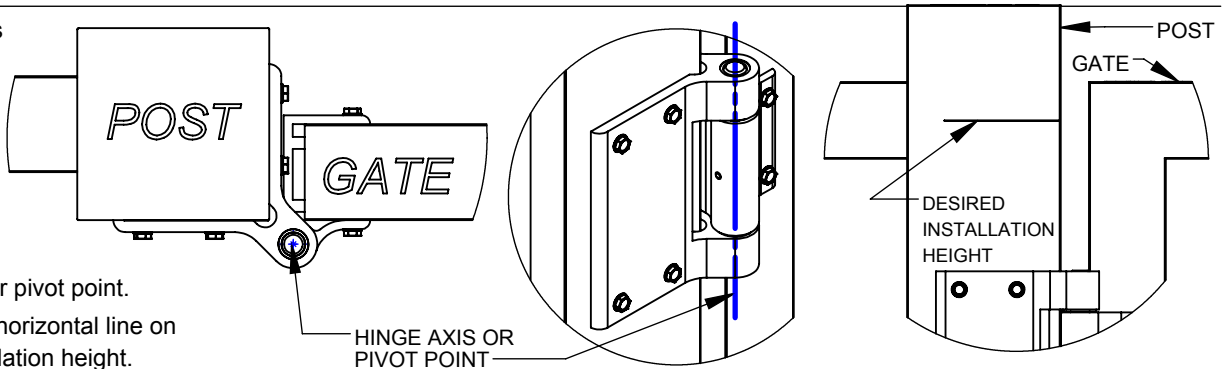

2A - Position the mounting template over or under either hinge with the hole marked "HINGE AXIS" Directly over the hinge axis or pivot point of the hinge.

2B - Slide the foot of the template out until it contacts the post. Rotate the template as needed until the foot is completely flat against the post. Double check the hole position to make sure it has not moved. Tighten screw on template to lock the foot into position.

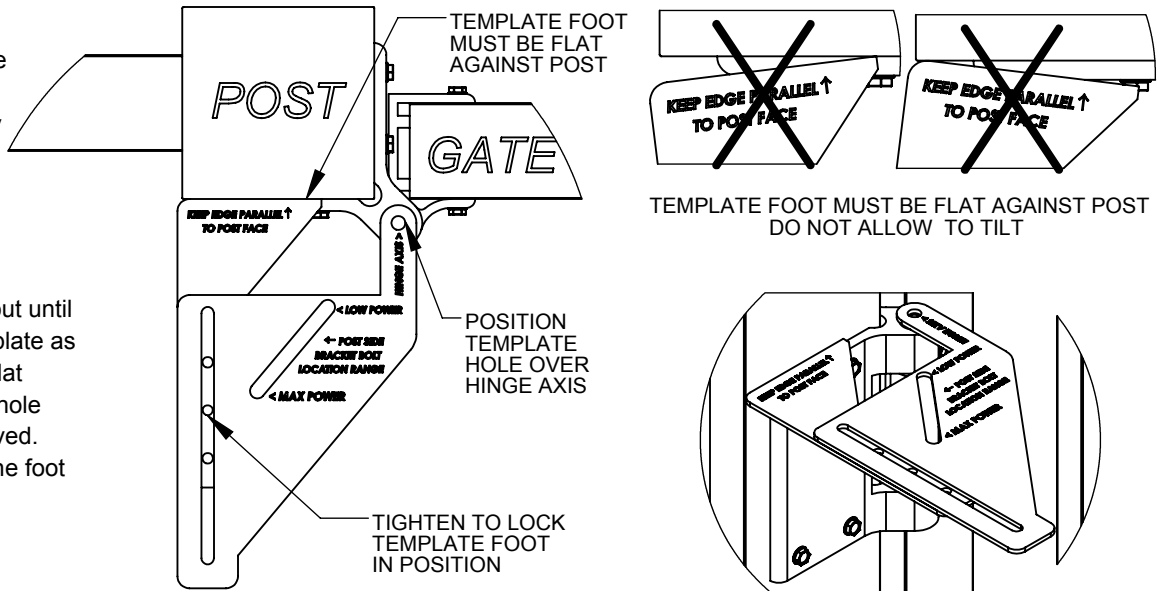

3A - Place post bracket over or under the template and flat against the post.

3B - Slide the post bracket horizontally along the template to find a position where a hole in the bracket lines up with the slot in the template.

NOTE 1: Multiple holes on the bracket may line up with the slot. For most applications, the mounting point should be as close as possible to the end of the slot in the template marked "MAX POWER".

NOTE 2: If a lower power setting is required, select a position closer to the "LOW POWER" end of the slot during installation. Using the "LOW POWER" position will reduce closing force by about 50%.

NOTE 3: The post bracket may be installed with the slope facing left or right as needed in most applications.

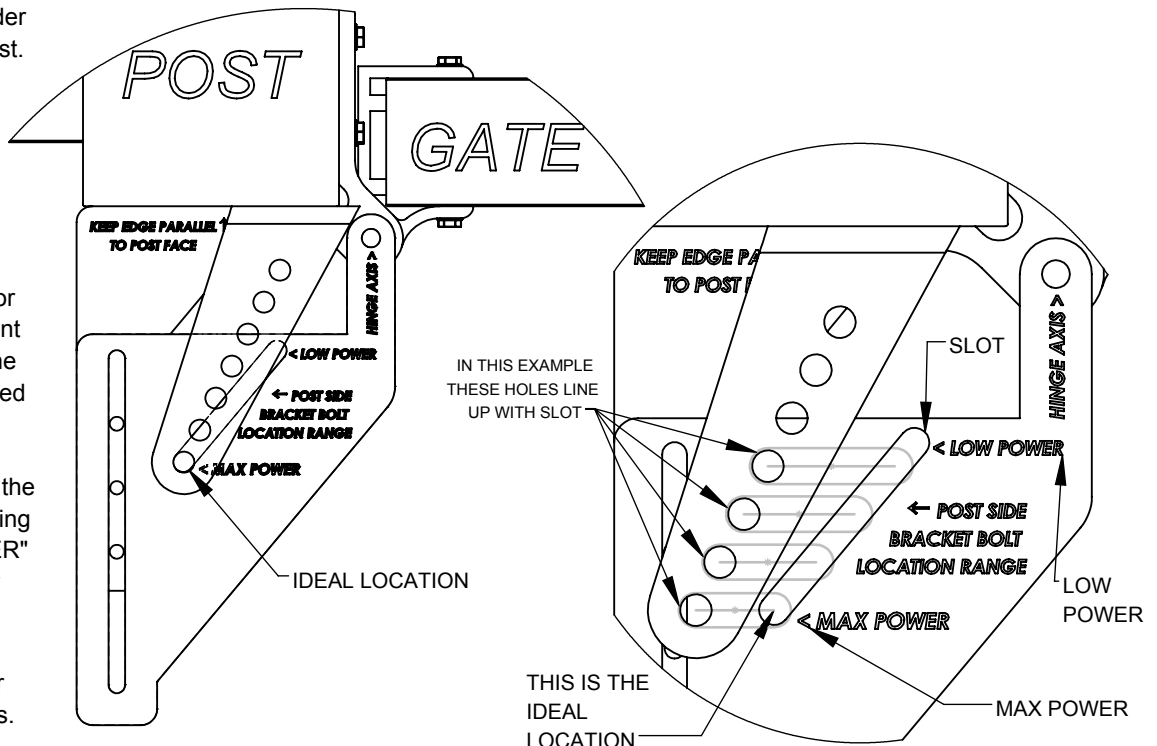

SHOTGUN® GATE CLOSER

www.nationwideindustries.com

INSTALLATION AND ADJUSTMENT INSTRUCTIONS

4 - Place the bolt through the post bracket and template and tighten nut enough to hold template in position.

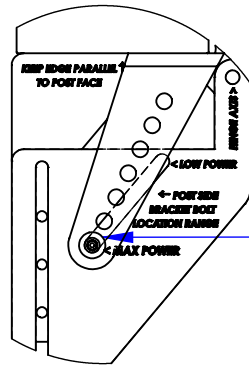

INSTALL NUT AND BOLT THEN TIGHTEN ENOUGH TO HOLD TEMPLATE IN POSITION

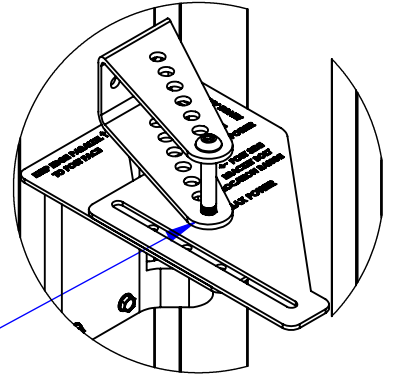

5 - Check to make sure the template and post bracket are still flat against the post and the hole is positioned correctly. Using a pencil, mark the post at the front (or back) edge of the post bracket as well as which hole the bolt is in.

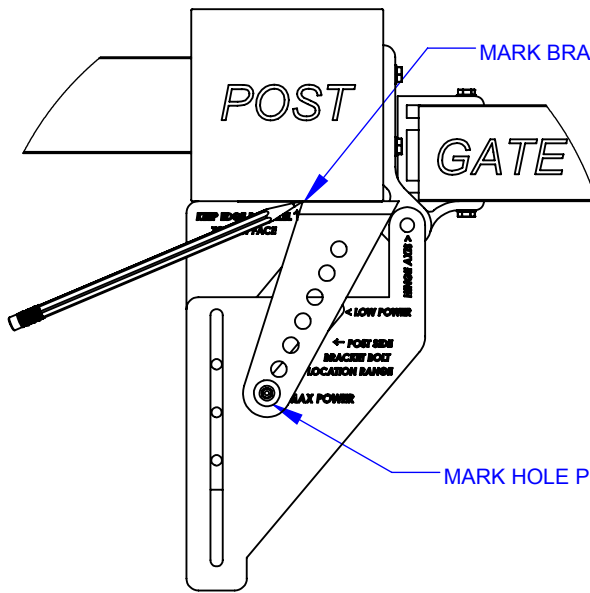

MARK BRACKET POSITION

MARK HOLE POSITION

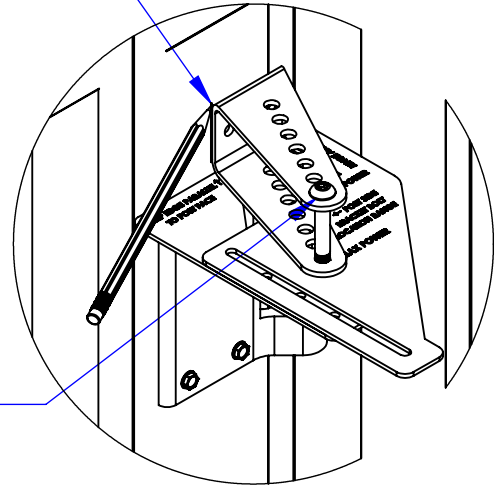

LINE MADE IN STEP 1C AT DESIRED MOUNTING HEIGHT

NEW LINE AT DESIRED MOUNTING HEIGHT

BOTH LINES ARE THE SAME DISTANCE FROM THE EDGE

TRANSFER THIS LINE TO MOUNTING LOCATION

6 - Measure to the location of the mark made in step 5 from the inside face of the post. Make another line at the desired mounting height using distance measured.

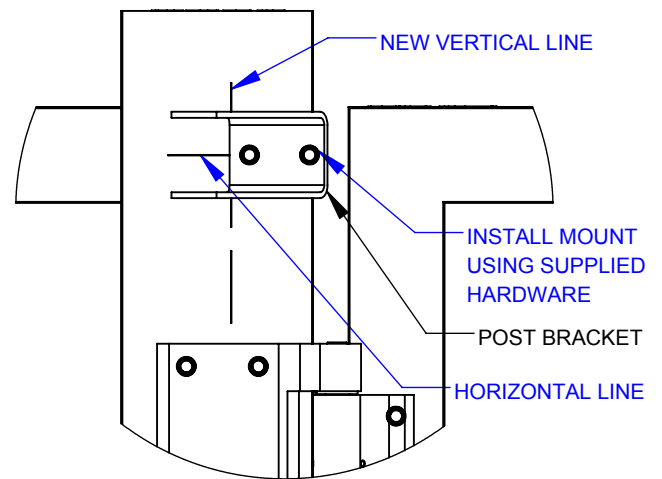
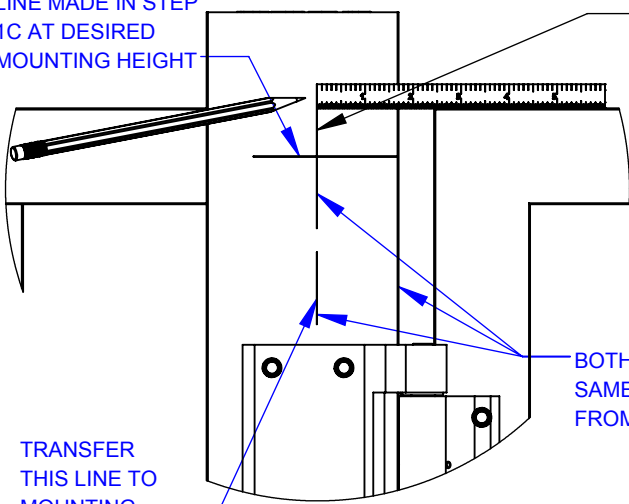

7 - Center post bracket over the horizontal line made in step 1C and next to the new vertical line made in step 6. Ensure the bracket is level and mark hole locations. Pre-drill holes if needed and attach the post bracket to the post using the included hardware.

SHOTGUN® GATE CLOSER

www.nationwideindustries.com

INSTALLATION AND ADJUSTMENT INSTRUCTIONS

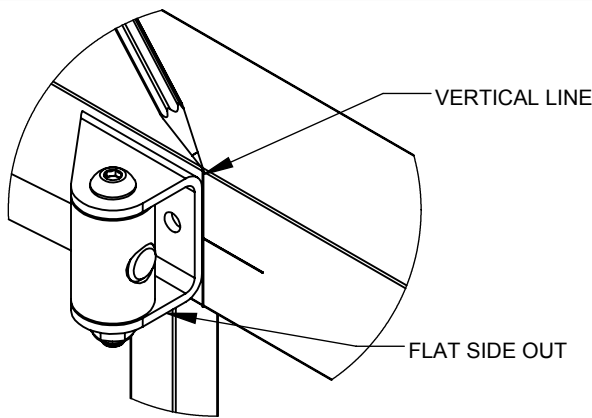
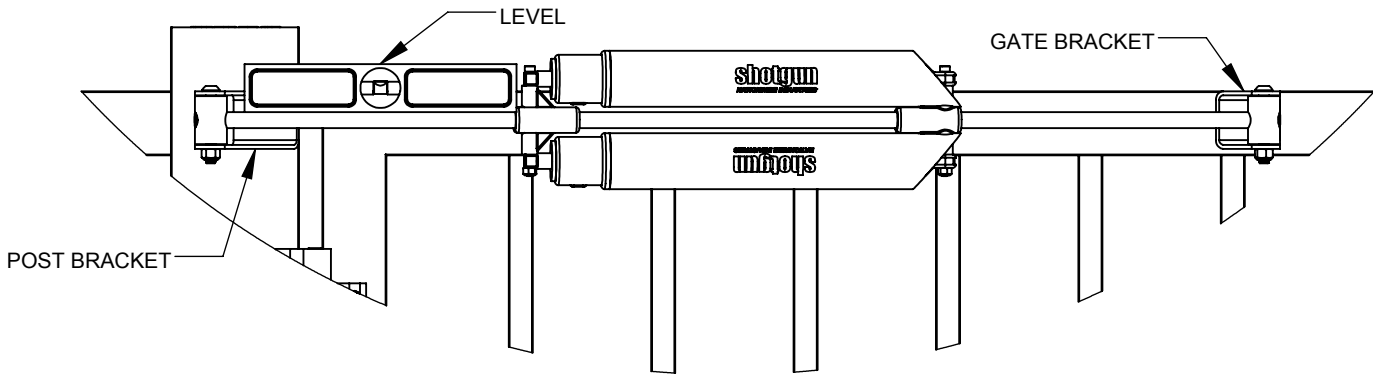

NOTE: The orientation of the gate bracket must be correct in every step.

8A - With the gate closed and latched, mount the gate bracket on the closer in the orientation shown above (flat side out) with the nut finger tight. Next, mount the closer assembly in the post bracket using the hole marked in step 5 with the nut finger tight. The closer must be held in position until the gate bracket has been installed.

8B - Level the closer assembly and draw a horizontal line marking the center of the gate bracket.

8C - Hold the gate bracket flat against the gate and gently push the gate bracket toward the post bracket to remove any slack then draw a vertical line at the end of the bracket.

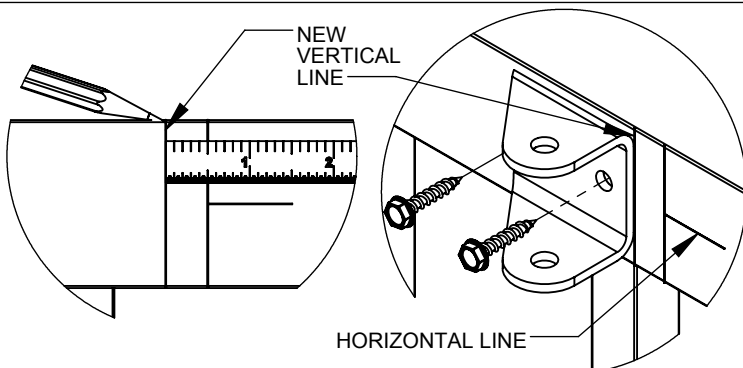

9A - Remove the closer and draw another vertical line $\frac{1}{2}$ " closer to the Post Bracket to preload the closer.

9B - Remove the gate bracket from the closer assembly and align it with the new vertical line while keeping it centered on the horizontal line made in step 8B. Mark the hole locations and predrill as required. Mount the gate bracket to the gate in this position using the supplied screws.

NOTE: The orientation of the gate bracket must be correct in every step.

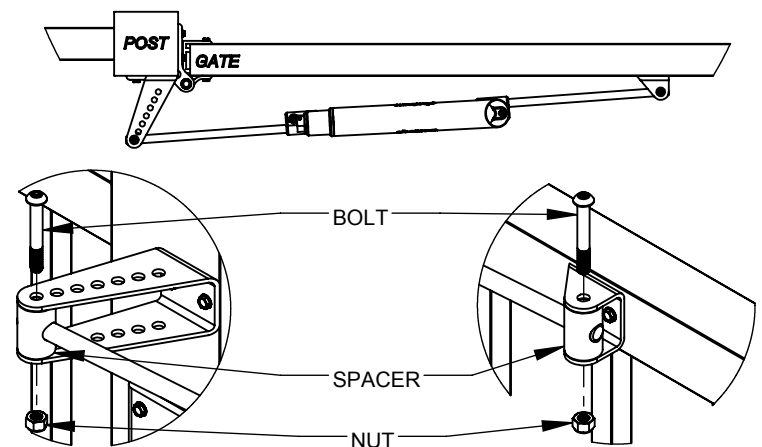

10 - Install the closer assembly in the post bracket in the orientation shown above using the mounting hole marked in step 5. To install the bolt in the gate bracket, the closer must be compressed by $\frac{1}{2}$ " to allow the bolt to pass through the rod. This can be done by grabbing the rod near the gate bracket and pulling toward the post bracket. Tighten both nuts until they contact the bracket, then back off $\frac{1}{2}$ turn.

11 - Check to ensure the gate opens, closes, and latches properly. The preload setting should hold the gate closed when the latch is opened.

12 - To adjust the closing speed of the gate, turn both adjustment screws clockwise until they seat then back off both by 1 turn and test the closing speed from fully open. To make the gate close faster, turn the screws counter-clockwise. To slow the closing speed, turn the screws clockwise. Ensure both adjustment screws are turned an equal amount from the seated position to equalize loading and wear.

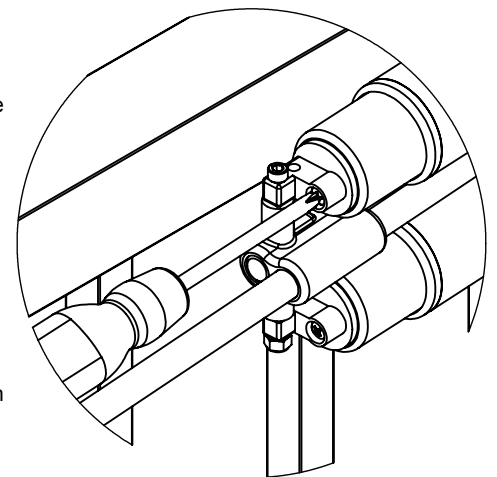

Note: To prevent damage, a gate stop must be installed to limit the gate from opening more than 90 degrees.