

PART #	COLOR
C2H300F-4D-BK	BLACK

		REVISIONS		
ECR/DCR	REV.	DESCRIPTION	DATE	APPD
-	-	INITIAL RELEASE	08-29-16	-
-	1	REVISED PART # TABLE	05-22-24	DDC

PACKAGING INSTRUCTIONS

POLYBAG CONTAINING:

- (2) HINGE ASSEMBLIES
- (2) HORIZONTAL BACKPLATES
- (2) VERTICAL BACKPLATES
- (1) INSTRUCTION SHEET
- (1) WARRANTY SHEET
- POLYBAG CONTAINING:

- (20) #12 X 1.25" FLAT HD PHILLIPS SD SCREWS (410 SS)
- (12) 1/4" FLAT WASHERS (18-8 SS)
- (12) 1/4"-20 ACORN NUTS (18-8 SS)
- (1) 1/4" HEX WRENCH

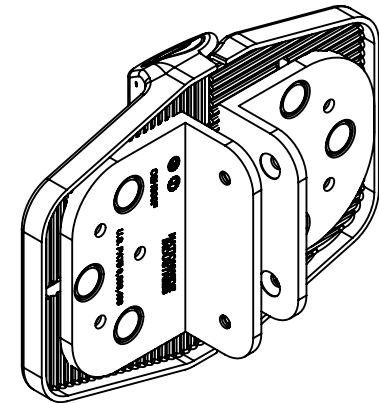
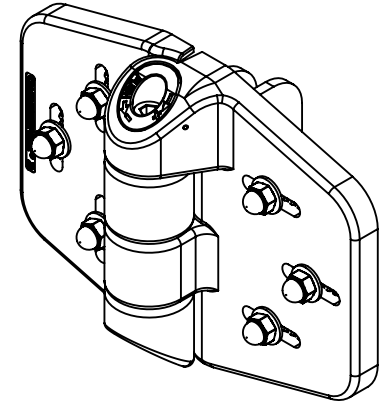
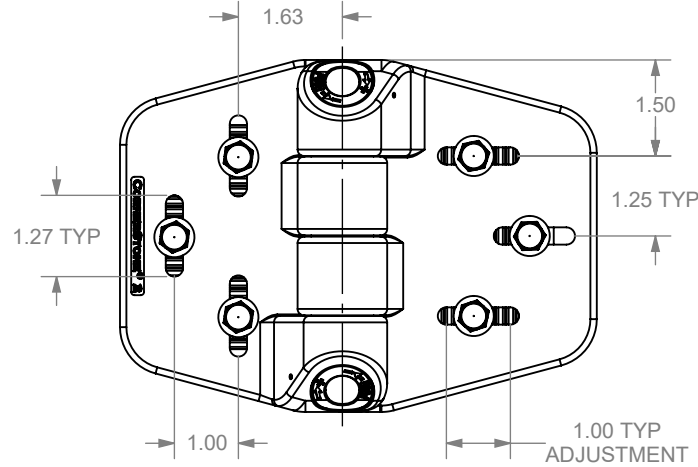
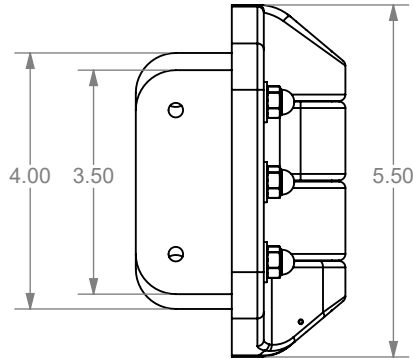
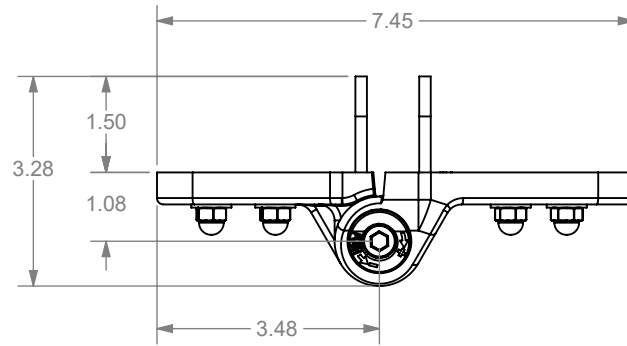

DIMENSIONS ARE IN INCHES TOLERANCES: FRACTIONAL $\pm 1/16"$ ANGULAR: MACH $\pm 1^\circ$ BEND $\pm 1^\circ$ TWO PLACE DECIMAL ± 0.01 THREE PLACE DECIMAL ± 0.005		NATIONWIDE INDUSTRIES® CORNERSTONE® 2 FULLY ADJUSTABLE HINGE 3"	
PROPRIETARY AND CONFIDENTIAL THE INFORMATION CONTAINED IN THIS DRAWING IS THE SOLE PROPERTY OF NATIONWIDE INDUSTRIES. ANY REPRODUCTION IN PART OR AS A WHOLE WITHOUT THE WRITTEN PERMISSION OF NATIONWIDE INDUSTRIES IS PROHIBITED.		SIZE A DWG. NO. CS--C2H300F SCALE: 1:3 WEIGHT:	REV. 1 SHEET 1 OF 1

PART #	COLOR
KLTRV-500-4D-BK	BLACK

REVISIONS		DESCRIPTION	DATE	APPD
ECR/DCR	REV.			
-	-	INITIAL RELEASE	05-23-24	-

PACKAGING INSTRUCTIONS

POLYBAG CONTAINING:

- (1) LATCH ASSEMBLY
- (1) KEEPER ASSEMBLY
- (1) INSTRUCTION SHEET
- (1) WARRANTY SHEET

POLYBAG CONTAINING:

- (4) #8 X 1" PAN HD PHILLIPS SD SCREWS - MATERIAL: 410 SS
- (5) #8 X 1" FLAT HD PHILLIPS SD SCREWS - MATERIAL: 410 SS

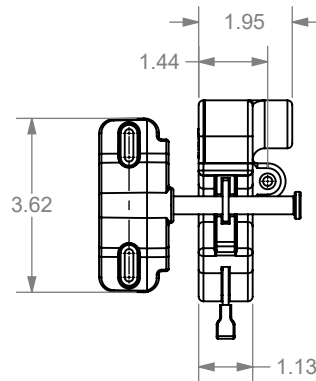
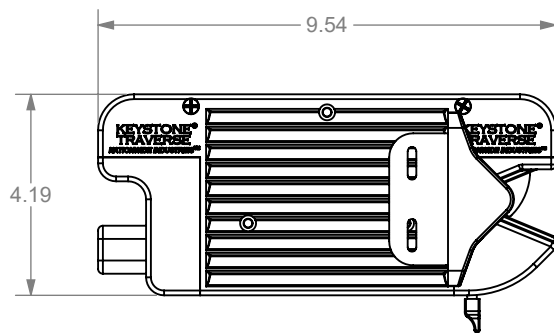
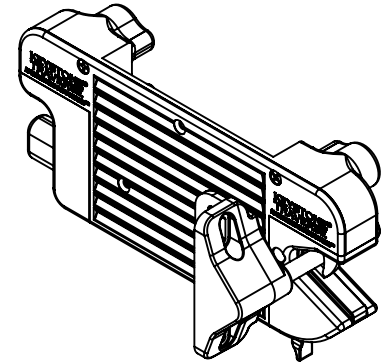
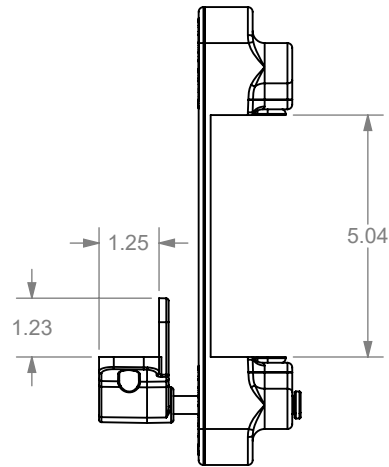

DIMENSIONS ARE IN INCHES TOLERANCES: FRACTIONAL $\pm 1/16"$ ANGULAR: MACH $\pm 1^\circ$ BEND $\pm 1^\circ$ TWO PLACE DECIMAL ± 0.01 THREE PLACE DECIMAL ± 0.005		NATIONWIDE INDUSTRIES®	
PROPRIETARY AND CONFIDENTIAL THE INFORMATION CONTAINED IN THIS DRAWING IS THE SOLE PROPERTY OF NATIONWIDE INDUSTRIES. ANY REPRODUCTION IN PART OR AS A WHOLE WITHOUT THE WRITTEN PERMISSION OF NATIONWIDE INDUSTRIES IS PROHIBITED.		KEYSTONE® TRAVERSE 2-SIDED LOCKING LATCH 5"	
SIZE A	DWG. NO.	CS--KLTRV-500	REV. -
SCALE: 1:4	WEIGHT:	SHEET 1 OF 1	

PART #	COLOR	SCREWS
NW314-BK	BLACK	NO
NW314-WHK	WHITE	NO
NW314S-B	BLACK	#8 X 1.25" FLAT HD PHILLIPS SD SCREWS (SS)
NW314S-W	WHITE	#8 X 1.25" FLAT HD PHILLIPS SD SCREWS (SS)

ECR/DCR		REV.	REVISIONS	DESCRIPTION	DATE	APPD
-	-	-	INITIAL RELEASE		04-26-07	-
-	-	1	UPDATED FORMAT		05-22-24	DDC

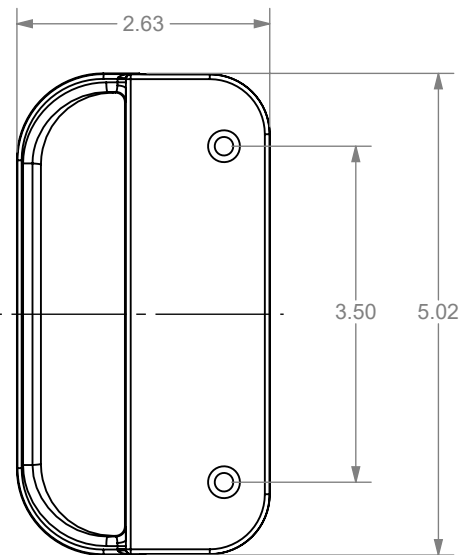
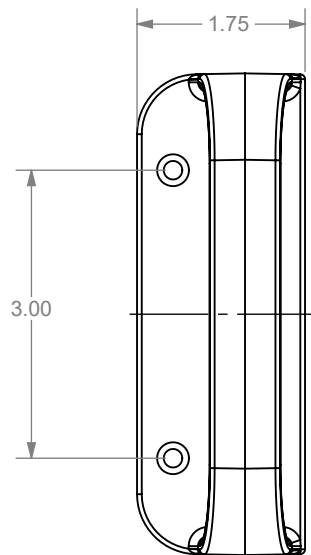
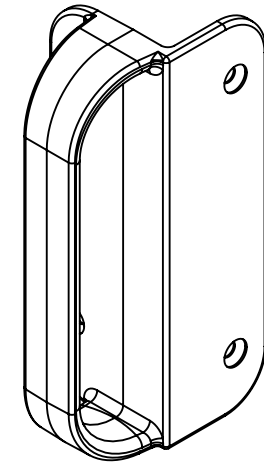
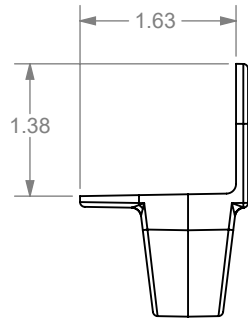

DIMENSIONS ARE IN INCHES TOLERANCES: FRACTIONAL $\pm 1/16"$ ANGULAR: MACH $\pm 1^\circ$ BEND $\pm 1^\circ$ TWO PLACE DECIMAL ± 0.01 THREE PLACE DECIMAL ± 0.005		NATIONWIDE INDUSTRIES®	
PROPRIETARY AND CONFIDENTIAL THE INFORMATION CONTAINED IN THIS DRAWING IS THE SOLE PROPERTY OF NATIONWIDE INDUSTRIES. ANY REPRODUCTION IN PART OR AS A WHOLE WITHOUT THE WRITTEN PERMISSION OF NATIONWIDE INDUSTRIES IS PROHIBITED.		PLASTIC GATE HANDLE	
SIZE: A DWG. NO.: CS--NW314 SCALE: 1:2 WEIGHT:	REV. 1	SHEET 1 OF 1	