

PART #	COLOR	SCREWS
CH090-4D-BK	BLACK	(16) #10 X 1" HEX WASHER HD SD SCREWS - MATERIAL: 410 SERIES SS

		REVISIONS		
ECR/DCR	REV.	DESCRIPTION	DATE	APPD
-	-	INITIAL RELEASE	12-13-13	-
DCR-0275	1	REVISED SD SCREW MATERIAL FROM 18-8 SS TO 400 SERIES SS	06-13-14	CGS
-	2	UPDATED TABLE	05-21-24	DDC

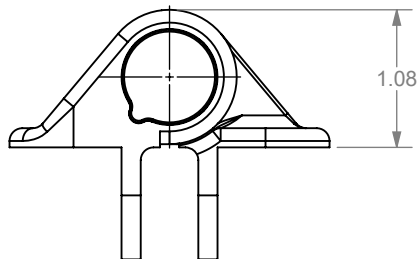
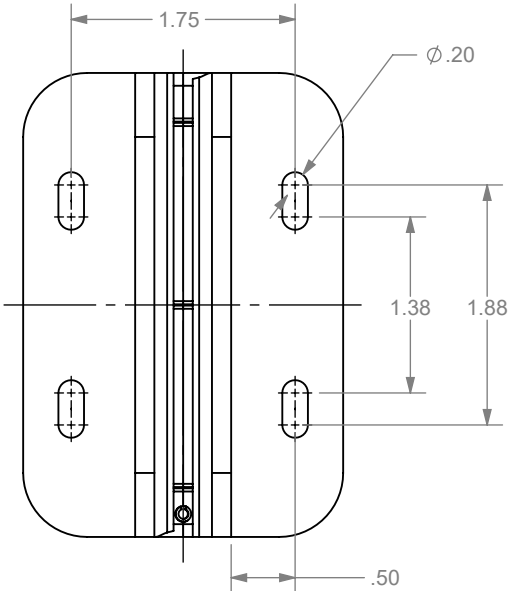
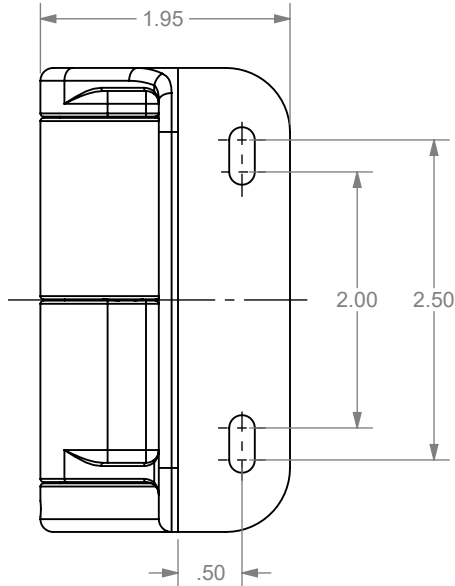
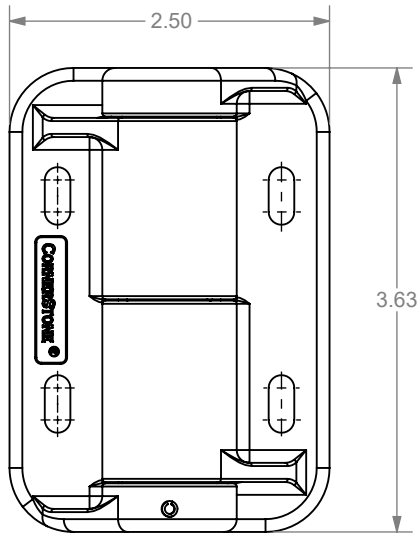
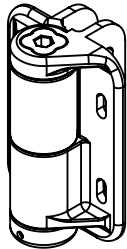
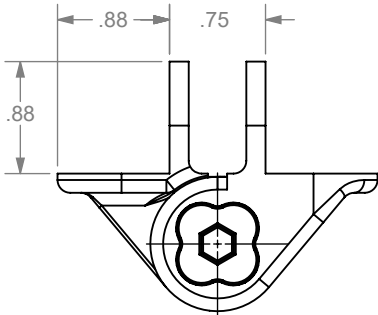

**PACKAGING INSTRUCTIONS**

**POLYBAG CONTAINING:**

- (2) HINGES
- (1) ADJUSTMENT WRENCH
- (1) INSTRUCTION SHEET
- (1) WARRANTY SHEET
- (1) POLYBAGGED SCREW PACK (SEE TABLE)

DIMENSIONS ARE IN INCHES  
TOLERANCES:  
FRACTIONAL ±1/16"  
ANGULAR: MACH ±1° BEND ±1°  
TWO PLACE DECIMAL ±0.01  
THREE PLACE DECIMAL ±0.005

PROPRIETARY AND CONFIDENTIAL  
THE INFORMATION CONTAINED IN THIS DRAWING IS THE SOLE PROPERTY OF NATIONWIDE INDUSTRIES. ANY REPRODUCTION IN PART OR AS A WHOLE WITHOUT THE WRITTEN PERMISSION OF NATIONWIDE INDUSTRIES IS PROHIBITED.

**NATIONWIDE INDUSTRIES®**

**ORNAMENTAL PLASTIC SELF-CLOSING HINGE**

SIZE <b>A</b>	DWG. NO. <b>CS--CH090</b>	REV. <b>2</b>
SCALE: 2:3	SHEET 1 OF 1	

<b>PART #</b>	<b>COLOR</b>
KLTRV-250-BK	BLACK

		REVISIONS		
ECR/DCR	REV.	DESCRIPTION	DATE	APPD
-	-	INITIAL RELEASE	05-21-24	DDC

**PACKAGING INSTRUCTIONS**

POLYBAG CONTAINING:

- (1) LATCH ASSEMBLY
- (1) KEEPER ASSEMBLY
- (1) INSTRUCTION SHEET
- (1) WARRANTY SHEET

- POLYBAG CONTAINING:

- (4) #8 X 1" PAN HD PHILLIPS SD SCREWS - MATERIAL: 410 SS
- (5) #8 X 1" FLAT HD PHILLIPS SD SCREWS - MATERIAL: 410 SS

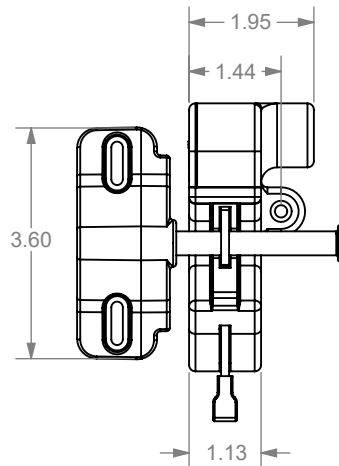
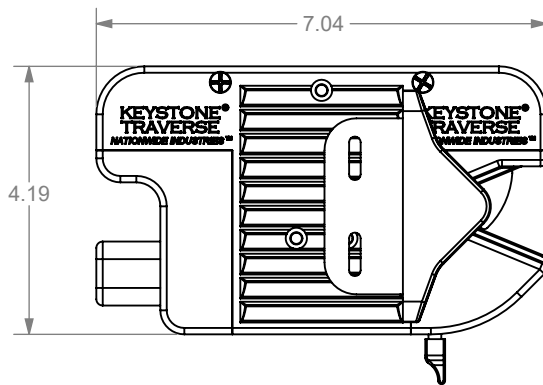
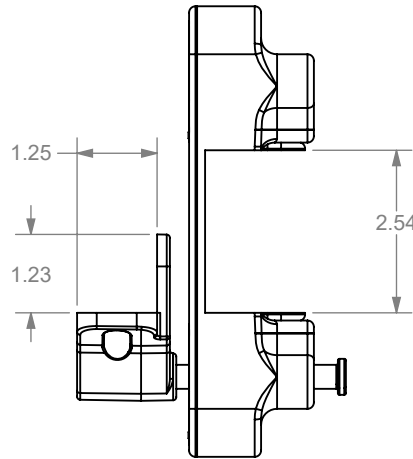
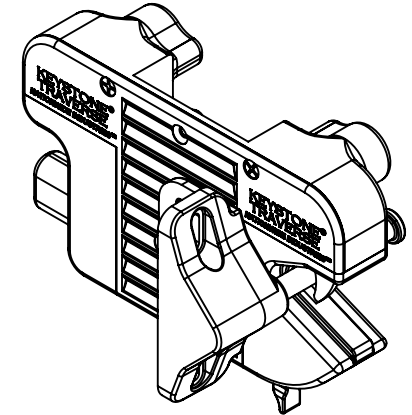

DIMENSIONS ARE IN INCHES TOLERANCES: FRACTIONAL $\pm 1/16"$ ANGULAR: MACH $\pm 1^\circ$ BEND $\pm 1^\circ$ TWO PLACE DECIMAL $\pm 0.01$ THREE PLACE DECIMAL $\pm 0.005$		<b>NATIONWIDE INDUSTRIES®</b>	
<b>PROPRIETARY AND CONFIDENTIAL</b> THE INFORMATION CONTAINED IN THIS DRAWING IS THE SOLE PROPERTY OF NATIONWIDE INDUSTRIES. ANY REPRODUCTION IN PART OR AS A WHOLE WITHOUT THE WRITTEN PERMISSION OF NATIONWIDE INDUSTRIES IS PROHIBITED.		<b>KEYSTONE® TRAVERSE 2-SIDED LOCKING LATCH 2.5"</b>	
SIZE: <b>A</b> SCALE: 1:3	DWG. NO.: <b>CS--KLTRV-250</b> WEIGHT:	REV. NO.: <b>-</b> SHEET 1 OF 1	REV. NO.: <b>-</b>