



The Horse Friendly Fence®

PLANNING **GUIDE**

Flexible Horse Fencing



**WOMEN
OWNED™**



HISTORY OF Centaur®

Centaur® flexible fence was developed because inventor, Ed Robbins, witnessed a tragic accident. A friend's horse became entangled in a wire fence and was euthanized due to extensive injury. That very moment Ed Robbins, an avid horseman, swore he would create fencing material that would be safer for horses.

Ed took a long hard look at what makes traditional fence materials a threat to horses and came up with a safer, long lasting alternative. Splinters, cracked boards, nails and fallen fence lines all pose a serious threat to equine safety. In 1981, Ed Robbins invented an effective fence solution that allows impact to be absorbed by the entire length of the fence. Backed by a series of patents, this new flexible rail offers a safer, more secure containment system than traditional fence materials.

We all have horses because we love them and our equestrian lifestyle. With Centaur® fencing systems in place, horses enjoy a safer environment while owners enjoy peace of mind.



Ed Robbins with his polo pony, Smokey, and his bird dog April.



Centaur® is proudly manufactured in Muscle Shoals, Alabama

In 2016 Ed Robbins was inducted into the Guinness Book of World Records as the oldest competing polo player in the world. (Ed Robbins in front)



WHAT MAKES Centaur® The Horse Friendly Fence®

Safer

Flexible rail absorbs impact.



Stronger

Each rail has up to 4,200 lbs of break strength. This helps provide sound perimeter protection against possible fallen trees and roadside damage.

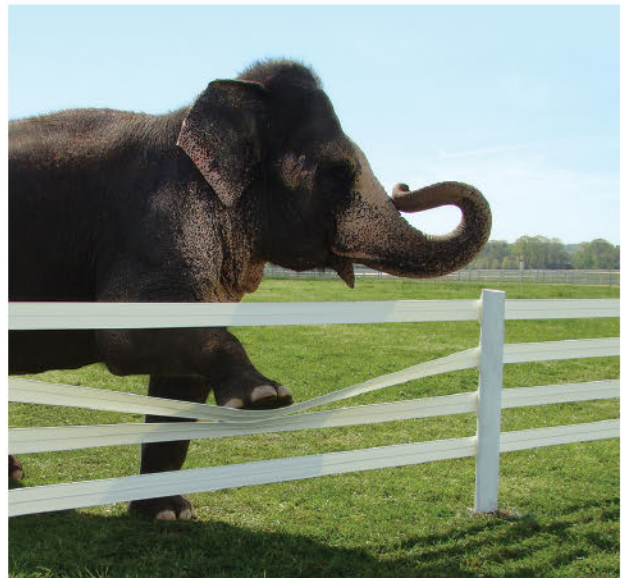

High Quality

Centaur is the inventor of High Tensile Polymer HTP®. The HTP® material is a blend of impact modifiers, UV stabilizers and anti-fungicides. This specialized formulation provides added durability, stain and mildew resistance.



Climate Tough

Withstands temperature conditions from -40°F / -40°C to 200°F / 93.3°C without becoming brittle or experiencing breakdown.



Low Maintenance

Will not splinter, rot, rust or crack. Minimal upkeep is required throughout the life of your fence. Simply adjust tension when needed.



Fast Installation

Centaur rail installs in a continuous length and does not need paint. Simply unroll, attach and adjust tension.





TABLE OF Contents

History of Centaur	2
What Makes Centaur	3
Centaur® Fence Test Farm	5
Selecting the Right Fence	6
Planning Your Fence Project.....	7
Centaur® Flexible 5" Rail	8, 9
Hot Rail® Electric Flexible 5" Rail	10, 11
CenFlex® Flexible 5" Rail.....	12, 13
White Lightning® Electric Safety Coated Wire	14, 15
PolyPlus Safety Coated Wire.....	16, 17
Fence System Configurations	18, 19
Rail Accessories	20, 21, 22
Strand Accessories.....	23, 24
Installation Tools and Hardware	25
Electric Fence Accessories	26
Vet Testimonials	27
Testimonials.....	28, 29
KleerFlex Door®	30
Fence Layout Grid	31



Centaur® FENCE TEST FARM

Developing and testing high quality fence systems.

Located in Elgin, Alabama, the Centaur Test Farm is home to 500+ acres, showcasing Centaur® fencing systems.

At Centaur® we take pride in developing, testing and manufacturing high quality products that provide safer containment options for your horses and beauty for your property.

We push Centaur® fencing and accessories to the limit. Take a look at Centaur in action and see for yourself why Centaur® is Safer, Stronger and Lasts Longer.

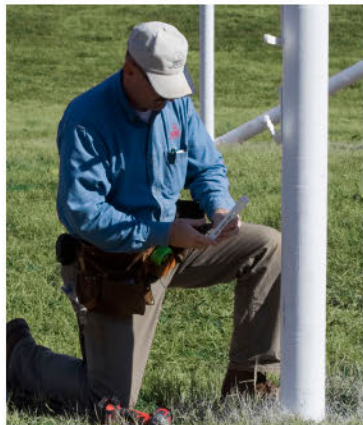

SELECTING The Right Fence

When choosing the best fence for your property, there are many factors to consider:

FENCE SAFETY - How does your fence material react when subjected to rubbing, leaning or impact?

Centaur's high tensile fence technology absorbs pressure along the continuous length of material, allowing the fence to rebound and help keep contained animals safe. Along with flexibility, Centaur® fence systems are smooth and do not splinter, rust, rot or crack. No fence product is 100% safe, however, Centaur® technology helps provide containment solutions that are safer than traditional fence materials.

- Braided rope fencing can break easily, and carries the risk of tangling the horse.
- Wood and rigid PVC boards can fall, shatter or splinter under pressure causing a dangerous breach or impalement on impact.
- Woven wire mesh contains spaces that may potentially trap a horse's hoof, especially a foal.

CONTAINMENT STRENGTH - What kind of animals do you own and how many do you wish to contain?

Reinforced flexible fencing, like Centaur®, is one of the strongest fencing options available. The size and temperament of your animals will help determine your needs. For example, an area designed to contain a stallion may require a four rail fence with eight foot post spacing while another for mares may only require three rails with a twelve foot post spacing. *Contact a Centaur fencing specialist to help you plan the best fence configuration for your application.*

COST AND MAINTENANCE - Budget considerations can be a factor when designing fencing projects.

Investing in Centaur® fencing systems provides long term savings when compared to high maintenance wood fence enclosures. Centaur® is virtually maintenance free. With no boards needing paint or replacement due to rotting and cribbing - very little upkeep is required throughout the life of your fence. With Centaur, enjoy a long lasting high tensile fencing system without the need for costly maintenance and continuous repairs.

EASE OF INSTALLATION - Much faster than traditional wood fence installation.

Centaur® fence systems install in continuous lengths. No painting required. Simply unroll, attach and adjust tension. Instruction manuals and on-line videos are available to guide you through the steps of installation. If you prefer the experience of a professional, please contact Centaur and we will connect you with a nearby installer.

APPEARANCE – Elegant, long lasting fence adds beauty to your property.

Centaur replicates the beauty of a traditional wood rail fence. However, Centaur fence systems have enduring qualities that provide a longer lasting investment than wood.

WARRANTY - Visit centaurhorsefence.com for more information.



- Centaur®
- Hot Rail®



- CenFlex®
- White Lightning®
- PolyPlus

PLANNING Your Fence Project

The first steps for a Centaur® Fence System quote.

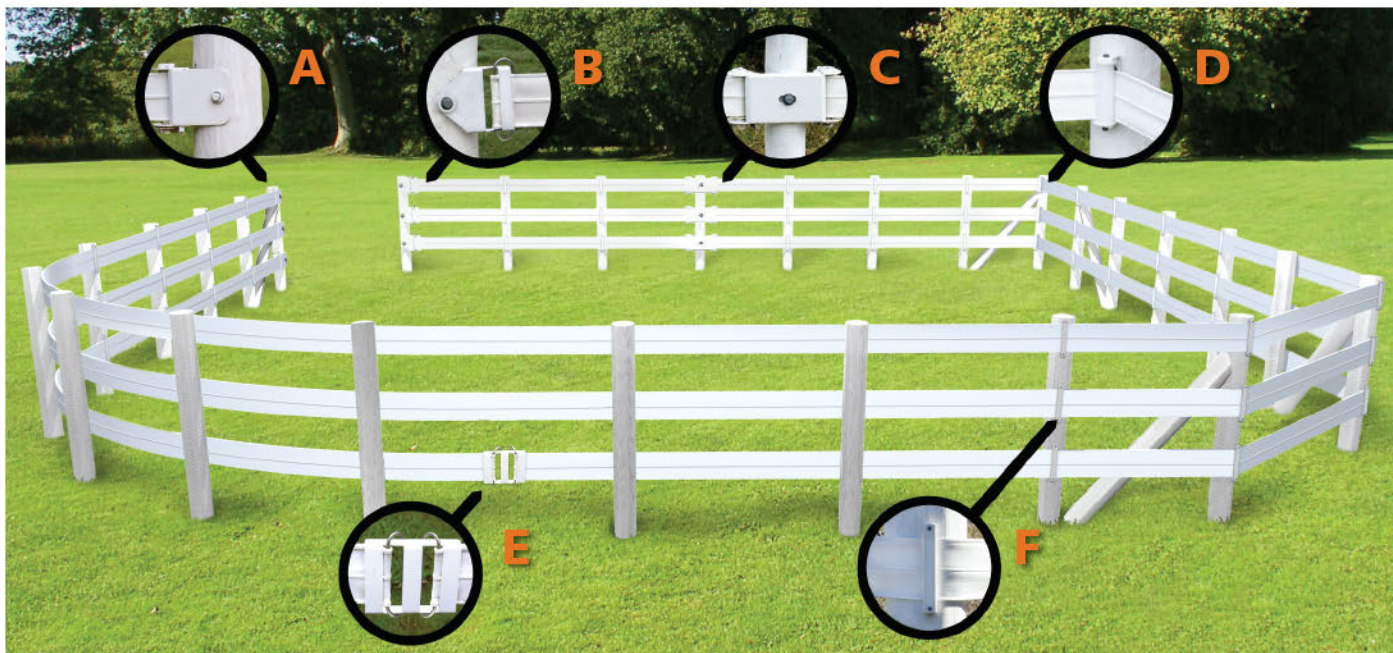

A. One Way Barrel Tensioner
B. Termination Bracket

C. Two Way Barrel Tensioner
D. Inside Corner Roller

E. Splice Buckle
F. Line Bracket

Sample Layout. A preliminary sketch of your fence layout will help with your estimate and parts recommendations. Please use page 31 for your fence sketch. If you need help please contact your Centaur® fence specialist for assistance.

- What is the total number of running feet of the area to be fenced?
- How many rails of fence do you want to install? Do you want electric?
- What post spacing do you want to use (8', 10', or 12')?
- Gate quantity, location and size.
- What type of corners are needed, 90 degree or 5 post rounded corner?
- Are you fencing level or irregular terrain?
- Will you install the fencing yourself or hire a professional?

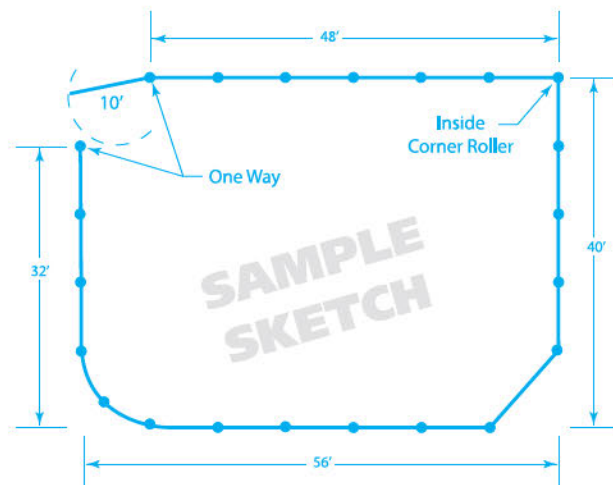

Total minus gate size: $48' + 40' + 56' + 32' + 10' = 186'$
 $186'$ (total) - $10'$ (gate size) = $176'$ (total without gate)

Multiply number of feet to be fenced by the number of desired rails to estimate total amount of fence needed. Be sure to subtract gated areas from rail totals.

GUIDE TO FENCING SQUARE ACRES

ACRES	FENCE NEEDED	ACRES	FENCE NEEDED	ACRES	FENCE NEEDED	ACRES	FENCE NEEDED
1/4 acre	417'	2 acres	1,182'	6 acres	2,046'	10 acres	2,640'
1/2 acre	590'	3 acres	1,446'	7 acres	2,208'	25 acres	4,176'
3/4 acre	722'	4 acres	1,670'	8 acres	2,361'	50 acres	5,904'
1 acre	834'	5 acres	1,867'	9 acres	2,504'	100 acres	8,348'

*Call for additional acres



FLEXIBLE 5" RAIL

Centaur® is our deluxe horse friendly fence system. Crafted with HTP®, a specialized blend of high tensile polymers, each rail is embedded with three strands of 12.5 gauge high tensile steel wire providing superior strength and flexibility.





Centaur® Two-Piece Line Bracket

Centaur's two-piece bracket, embedded with a steel reinforced bar, is virtually indestructible. This exclusive two-piece "belt loop" design allows the fence rail to move freely through the bracket. This promotes easy tension adjustment and flexibility upon impact. Works with both Centaur® (non-electric) and Hot Rail® (electric) flexible rail systems.

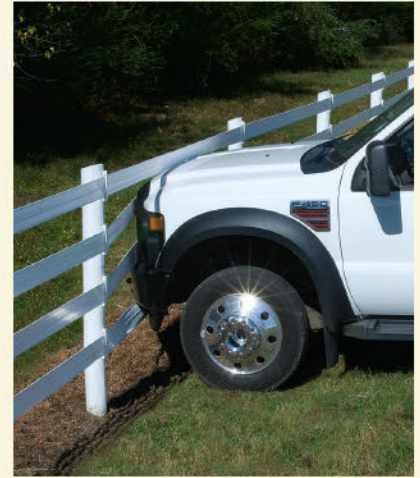

Superior Flexibility

Centaur® Barrel Tensioners

Crafted from heavy duty steel and powder coated to help prevent corrosion.



Centaur® Fence System

DELUXE PREMIUM SUPER

- Deluxe HTP® Polymer thickness for extra durability.
- Innovative two-piece "belt loop" line bracket system for optimal attachment.

Centaur® Sure-Fit® Accessory Checklist	Wood Line Post	End or Corner Post	Installation Accessory
Centaur® Two-Piece Line Bracket	✓		
Termination Bracket		✓	
Termination Loop		✓	
One-Way Barrel Tensioner		✓	
Two-Way Barrel Tensioner	✓		
Inside Corner Roller		✓	
T-Bracket		✓	
Splice Buckle			✓
2.5" Screws			✓
3.5 - 5" Ring Shank Nails			✓
Spinning Jenny			✓

*Centaur® Rail cannot be installed on T-Posts. *See pages 20 - 22 for more Sure-Fit® Rail Accessories

RAIL SPECIFICATIONS

- » 4,200 lbs of strength per rail
- » Withstands -40°F / -40°C to 200°F / 93.3°C
- » Available in 330' or 660' rolls
- » 30 Year Limited Warranty

Centaur® 5" Rail is easily combined with other Centaur® rail and strand fencing. See pages 18 and 19 for fence configuration options.



LEXINGTON

Hot Rail®
Centaur®
Centaur®
Centaur®



OCALA

Centaur®
Centaur®
Centaur®
Centaur®



WELLINGTON

Centaur®
White Lightning®
Centaur®
White Lightning®
Centaur®



FLEXIBLE 5" RAIL

Electric Hot Rail® combines the high tensile safety of Centaur® with the added security of an electric fence.



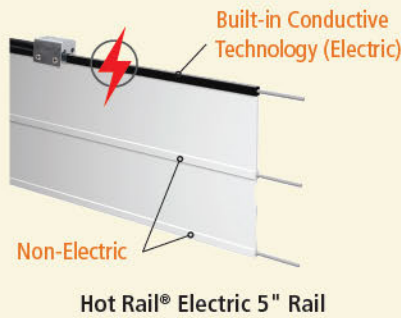

Hot Rail® contains a conductive bead that eliminates the need for a separate hot wire installation. This innovative hybrid rail technology has all the features of a Centaur® fence system with the added benefit of an electric charge.



Hot Rail® technology eliminates the need for a separate hot wire installation. Deters cribbing while promoting perimeter safety and respect.



The Snake Eyes® Electrical Connector is specifically designed for Hot Rail® and White Lightning® electric fence systems. Snake Eyes® attaches in seconds and has two stinger channels for easy rail to rail (or rail to strand) electric connections.



Hot Rail® Fence System

DELUXE PREMIUM SUPER

- Integrated electric bead.
- Deluxe HTP® Polymer thickness for extra durability.
- Innovative two-piece "belt loop" line bracket system for optimal attachment.

Hot Rail® Sure-Fit® Accessory Checklist	Wood Line Post	End or Corner Post	Installation Accessory
Centaur® Two-Piece Line Bracket	✓		
Hot Rail® Termination Bracket		✓	
Hot Rail® One-Way Barrel Tensioner		✓	
Two-Way Barrel Tensioner	✓		
ISO Pad (required with Two-Way)	✓		
Inside Corner Roller		✓	
Splice Buckle			✓
2.5" Screws			✓
3.5 - 5" Ring Shank Nails			✓
Undergate Cable			✓
Snake Eyes® Electrical Connector			✓
Cutoff Switch			✓
Energizer			✓
Fault Finder			✓
Spinning Jenny			✓

*Hot Rail® cannot be installed on T-Posts. *See pages 20 - 22 for more Sure-Fit® Rail Accessories

RAIL SPECIFICATIONS

- » 4,200 lbs of strength per rail
- » Withstands -40°F / -40°C to 200°F / 93.3°C
- » Available in 330' or 660' rolls
- » 30 Year Limited Warranty

Concerned with cribbing or unwanted large predators? Consider incorporating Hot Rail® into your fence configuration for ultimate perimeter strength, safety and respect. See pages 18 and 19.



Hot Rail®
Centaur®
Centaur®
Centaur®



Hot Rail®
CenFlex®
CenFlex®
Hot Rail®



Hot Rail®
PolyPlus
PolyPlus
PolyPlus
PolyPlus



FLEXIBLE 5" RAIL

CenFlex® flexible fence systems provide strength and safety at a lower cost for moderate installation budgets.



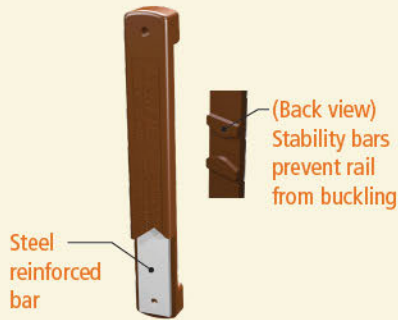

CenFlex® One-Piece Line Bracket

The CenFlex® one-piece bracket is specially designed for the CenFlex® (non-electric) fence system. This simple one-piece “belt loop” design allows the fence rail to move freely between the line bracket and wood fence post. This promotes easy tension adjustment and flexibility upon impact.



Impact Resistant

Rail installation along the inside of your fence line reduces interaction with posts and bracing structures. Centaur’s high tensile rail (electric or non-electric) glides along the Sure-Fit® Inside Corner Roller, promoting easier tensioning and smoother directional changes.



Inside Corner Roller



CenFlex® Fence System

DELUXE **PREMIUM** SUPER

- Standard HTP® Polymer material.
- Ideal for moderate fence budgets.
- Simple one-piece “belt loop” line bracket system.

CenFlex® Sure-Fit® Accessory Checklist	Wood Line Post	End or Corner Post	Installation Accessory
CenFlex® One-Piece Line Bracket	✓		
Termination Bracket		✓	
Termination Loop		✓	
One-Way Barrel Tensioner		✓	
Two-Way Barrel Tensioner	✓		
Inside Corner Roller		✓	
T-Bracket		✓	
Splice Buckle			✓
2.5" Screws			✓
3.5 - 5" Ring Shank Nails			✓
Spinning Jenny			✓

CenFlex® Rail cannot be installed on T-Posts. *See pages 20 - 22 for more Sure-Fit® Rail Accessories

RAIL SPECIFICATIONS

- » 4,200 lbs of strength per rail
- » Withstands -40°F / -40°C to 200°F / 93.3°C
- » Available in 330' or 660' rolls
- » 20 Year Limited Warranty

CenFlex® 5" Rail is easily combined with other Centaur® rail and strand fencing. See pages 18 and 19 for fence configuration options.



AIKEN

Hot Rail®
CenFlex®
CenFlex®
Hot Rail®



DEL MAR

CenFlex®
CenFlex®
CenFlex®



WEATHERFORD

CenFlex®
PolyPlus
CenFlex®
PolyPlus
CenFlex®



ELECTRIC SAFETY COATED HIGH TENSILE WIRE

White Lightning® is a permanent electric high tensile wire fence system. The 12.5 gauge high tensile steel wire is embedded in a polymer & carbon coating that promotes visibility and safety.



White Lightning® contains three carbon veins for optimum conductivity. This three point shock design provides 360 degrees of charge promoting ultimate fence respect.

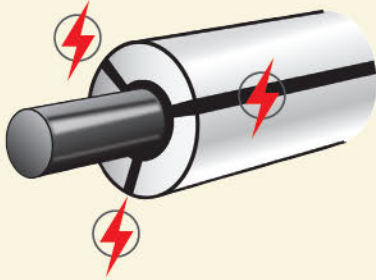

Three Point Shock Technology

Sure-Fit® T-Post Covers add safety to your fence. The innovative Sure-Fit® T-Post Safety Sleeve converts standard metal T-Posts into an attractive and safer post. No additional insulators needed when used with White Lightning® (electric) coated wire fence.

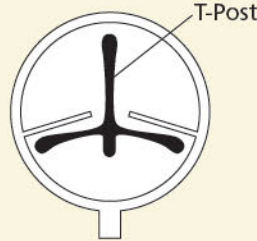

Sure-Fit® Safety Sleeve fits securely over standard metal T-Posts.



White Lightning® Fence System

DELUXE PREMIUM **SUPER**

- Three point shock technology provides 360 degrees of charge.
- Embedded carbon veins for optimum conductivity.
- Safety coated
- Sure-Fit® T-Post Safety Sleeve compatible.
- Color coating options to promote visibility.

STRAND SPECIFICATIONS

- » 1,400 lbs of strength per strand
- » Withstands -40°F / -40°C to 200°F / 93.3°C
- » Available in 1,320' rolls
- » 20 Year Limited Warranty

White Lightning® Accessory Checklist	Wood Line Post	End or Corner Post	T-Post	Installation Accessory
Insulated Fencer's Lasso®		✓		
Lag Corner Insulator		✓		
Wood Post Insulator	✓			
PolyPlus Quick End		✓		
Insultube	✓	✓		
T-Post Insulator			✓	
Sure-Fit® T-Post Safety Sleeve & T-Sleeve Clips			✓	
Wire Links				✓
Barbed Staples				✓
Undergate Cable				✓
Snake Eyes® Electrical Connector				✓
Cutoff Switch				✓
Energizer				✓
Fence Alert				✓
Fault Finder				✓
Tensioner Handle				✓
Spinning Jenny				✓

*See pages 23 - 24 for more White Lightning® Strand Accessories

White Lightning® is easily combined with other Centaur® rail and strand fencing. See pages 18 and 19 for fence configuration options.



COLUMBUS

White Lightning® PolyPlus
White Lightning® PolyPlus
White Lightning® PolyPlus



WELLINGTON

Centaur® 5"
White Lightning® Centaur® 5"
White Lightning® Centaur® 5"

PolyPlus



SAFETY COATED HIGH TENSILE WIRE

PolyPlus is a permanent non-electric high tensile coated wire fence system. The 12.5 gauge high tensile steel wire is embedded in a polymer coating for a safer and more visible wire fence.

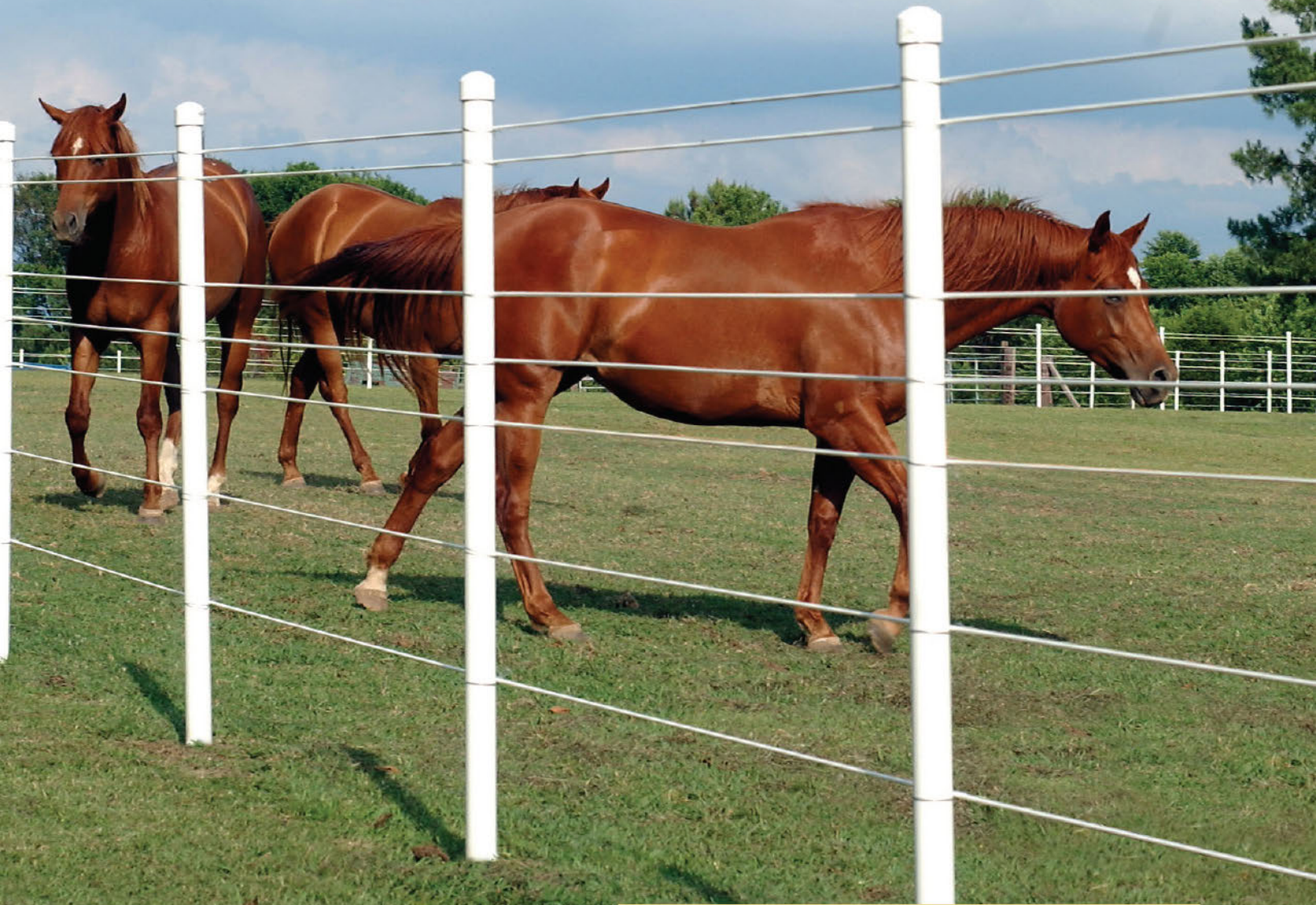

WHITE

BLACK

BROWN



Insulated Fencer's Lasso®

PolyPlus contains your horses and is safer than barbed wire and non-coated high tensile wire.

Quality tensioners help make fence maintenance quick and easy. The Fencer's Lasso® Insulated Ratchet Style Tensioner has built-in insulation and preattached cable loop for fast attachment to end termination posts. Easily maintains tension of White Lightning® (electric) or PolyPlus (non-electric) coated wire fence.



The Tensioner Handle makes tension adjustment quick and easy.



Combine PolyPlus with CenFlex® 5" Rail for increased visibility.



PolyPlus Fence System

DELUXE **PREMIUM** **SUPER**

- Safety coated
- Sure-Fit® T-Post Safety Sleeve compatible.
- Color coating options to promote visibility.

STRAND SPECIFICATIONS

- » 1,400 lbs of strength per strand
- » Withstands -40°F / -40°C to 200°F / 93.3°C
- » Available in 1,320' rolls
- » 20 Year Limited Warranty

PolyPlus Accessory Checklist	Wood Line Post	End or Corner Post	T-Post	Installation Accessory
Insulated Fencer's Lasso®		✓		
Lag Corner Insulator		✓		
Wood Post Insulator	✓			
PolyPlus Quick End		✓		
T-Post Insulator			✓	
Sure-Fit® T-Post Safety Sleeve			✓	
T-Sleeve Clips			✓	
Wire Links				✓
Barbed Staples				✓
Tensioner Handle				✓
Spinning Jenny				✓

*See pages 23 - 24 for more PolyPlus Strand Accessories

PolyPlus is easily combined with other Centaur® rail and strand fencing. See pages 18 and 19 for fence configuration options.



WEATHERFORD

CenFlex®
PolyPlus
CenFlex®
PolyPlus
CenFlex®



SCOTTSDALE

Hot Rail®
PolyPlus
PolyPlus
PolyPlus
PolyPlus



COLUMBUS

White Lightning®
PolyPlus
White Lightning®
PolyPlus
White Lightning®

FENCE SYSTEM CONFIGURATIONS

Optional fencing combinations using 5" rail and coated wire products.

■ **Non-Electric Fencing**

■ **Electric Fencing** ⚡



LEXINGTON

- Hot Rail® 5"
- Centaur® 5"
- Centaur® 5"
- Centaur® 5"

- The electric top rail helps prevent cribbing and promotes perimeter respect.
- Combines electric and non-electric fencing.



AIKEN

- Hot Rail® 5"
- CenFlex® 5"
- CenFlex® 5"
- Hot Rail® 5"

- The electric top & bottom rails discourage reaching over/ underneath fence lines. Electric bottom rail also may help deter large predators from crawling underneath the fence.
- Combines electric and non-electric fencing.



OCALA

- Centaur® 5"
- Centaur® 5"
- Centaur® 5"
- Centaur® 5"

- Deluxe Centaur® (four or three rail installation) for a durable perimeter with a classic estate look.
- Non-electric fencing.



DEL MAR

- CenFlex® 5"
- CenFlex® 5"
- CenFlex® 5"
- CenFlex® 5"

- Premium CenFlex® (three or four rail installation) for strength and safety benefits at a lower cost for moderate budgets.
- Non-electric fencing.

AVAILABLE COLORS



WHITE



BLACK



BROWN

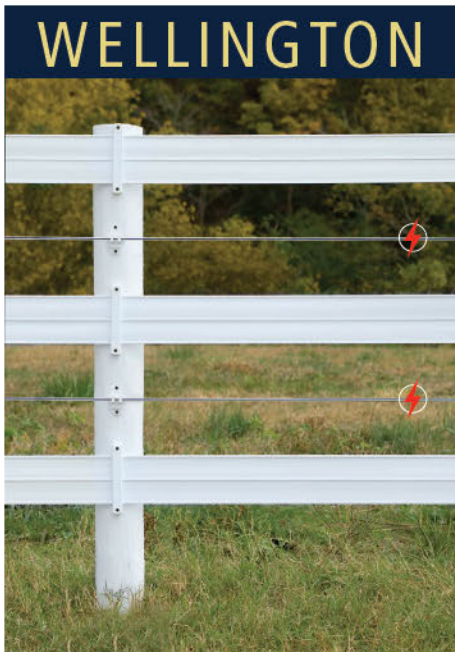

WELLINGTON

- Centaur® 5"**
- White Lightning®**
- Centaur® 5"**
- White Lightning®**
- Centaur® 5"**

- This configuration has the open look of a three rail system with the added benefit of an electric safety coated wire barriers. Ideal for discouraging reaching through fence rails.
- Combines electric and non-electric fencing.



WEATHERFORD

- CenFlex®**
- PolyPlus**
- CenFlex®**
- PolyPlus**
- CenFlex®**

- Open three rail system with additional safety coated wire barriers. Non-electric version of the Wellington combination at a lower cost for moderate budgets.
- Non-electric fencing.

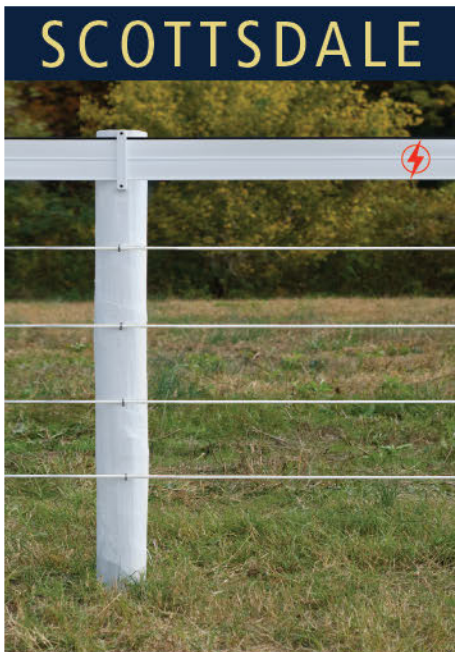

SCOTTSDALE

- Hot Rail®**
- PolyPlus**
- PolyPlus**
- PolyPlus**
- PolyPlus**

- The electric top rail helps prevent cribbing and promotes perimeter visibility when combined with safety coated wire.
- Combines electric and non-electric fencing.

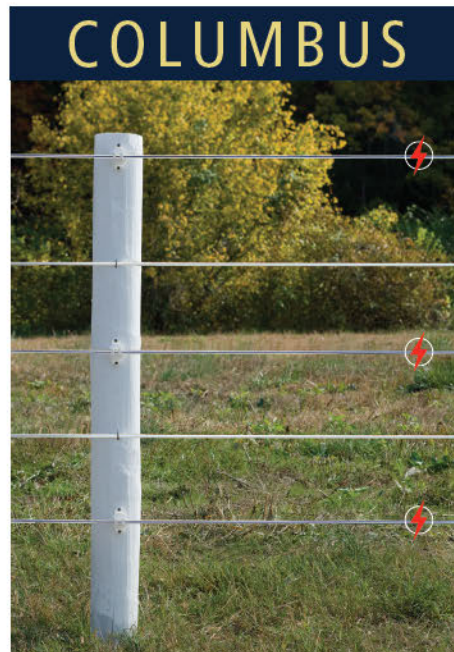

COLUMBUS

- White Lightning®**
- PolyPlus**
- White Lightning®**
- PolyPlus**
- White Lightning®**

- This configuration alternates electric and non-electric safety coated wire. The ultimate coated wire combination for discouraging reaching over, through and underneath fence lines. Electric bottom strand also may help deter large predators from crawling underneath the fence.
- Combines electric and non-electric fencing.

RAIL Accessories

Centaur's Sure-Fit® Accessories are designed to provide a wide range of options when it comes to designing and installing your Centaur® fencing system. All components are produced to the highest quality standards, assuring you a fence installation that will stand the test of time.

SURE-FIT® ACCESSORIES

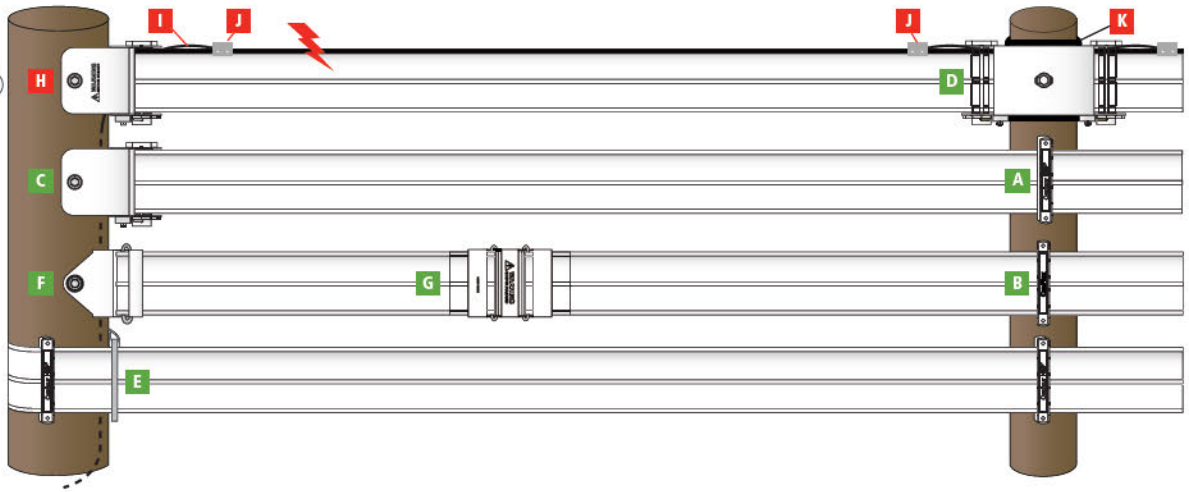

- | | | | |
|-----------------------------------|---|--|--|
| A Centaur® Line Bracket | D Two-Way Barrel Tensioner
(ISO Pad required when used with Hot Rail) | G Splice Buckle | J Snake Eyes®
Electrical Connector |
| B CenFlex® Line Bracket | E Termination Loop | H Hot Rail One-Way Barrel Tensioner | K Insulator Pad |
| C One-Way Barrel Tensioner | F Termination Bracket | I Undergate Cable | |

■ Non-electric fencing and accessories ■ Electric fencing and accessories



Hot Rail® Flexible Fence Rolls

Electric rail contains a conductive top bead and three strands of 12.5 gauge high tensile steel wire embedded in Deluxe HTP® polymer material. 30-Year Limited Warranty

- | | | |
|--------------------------|--------------------------|--------------------------|
| 381080 White 660' | 381083 Black 660' | 381086 Brown 660' |
| 381081 White 330' | 381084 Black 330' | 381087 Brown 330' |



Centaur® Flexible Fence Rolls

Three strands of 12.5 gauge high tensile steel wire embedded in Deluxe HTP® polymer material. 30-Year Limited Warranty

- | | | |
|--------------------------|--------------------------|--------------------------|
| 381000 White 660' | 381003 Black 660' | 381006 Brown 660' |
| 381001 White 330' | 381004 Black 330' | 381007 Brown 330' |



CenFlex® Flexible Fence Rolls

Three strands of 12.5 gauge high tensile steel wire embedded in Premium HTP® polymer material. 20-Year Limited Warranty

- | | | |
|--------------------------|--------------------------|--------------------------|
| 381050 White 660' | 381053 Black 660' | 381056 Brown 660' |
| 381051 White 330' | 381054 Black 330' | 381057 Brown 330' |



Centaur®/Hot Rail® Two Piece Line Bracket

Deluxe two-piece belt loop bracket system. HTP® coated steel core for added strength and durability. No additional insulation required when used with Hot Rail® fencing systems.

- | | | |
|---------------------|---------------------|---------------------|
| 385061 White | 385062 Black | 385063 Brown |
|---------------------|---------------------|---------------------|



CenFlex® One Piece Line Bracket

Simple one-piece belt loop bracket system. HTP® coated steel core for added strength and durability. For CenFlex® fencing systems only.

385070 White 385074 Black 385078 Brown



One-Way Barrel Tensioner

Designed to terminate and tension 5" rail around corners and straight lengths up to 660 feet (for every major directional change, deduct 100 feet). Needs to be installed on a 6 to 8 inch wood termination post. For Centaur® and CenFlex® fence systems only.

385123 White 385124 Black 385125 Brown



Hot Rail® One-Way Barrel Tensioner

Insulated tensioner used to terminate and tension 5" rail around corners and straight lengths up to 660 feet (for every major directional change, deduct 100 feet). Needs to be installed on a 6 to 8 inch wood termination/end post. For Hot Rail® fence systems only.

385456 White 385457 Black 385458 Brown



Two-Way Barrel Tensioner

Ideal for splicing long runs of 5" rail and tensioning around corners and straight lengths up to 660 feet in each direction for a total combined length of 1,320 feet (for every major directional change, deduct 100 feet). Needs to be installed on a 6 to 8 inch wood termination/end post. ISO insulation pad required when used with Hot Rail® fence systems.

385147 White 385148 Black 385149 Brown



Splice Cover

Attractively conceals rail splices. Easy to install covers protect wire link splices from the elements and curious horses. Wire links not included, three links needed for each splice cover.

385227 White 385228 Black 385229 Brown



Sure-Hook® Termination Bracket

Anchors the end of the 5" rail to the wood termination post. No wire stripping or special tools needed. Needs to be installed on a 6 to 8 inch wood termination/end, or gate post. For Centaur® and CenFlex® fence systems only.

385443 White 385444 Black 385445 Brown



Hot Rail® Termination Bracket

Insulated anchor for attaching 5" electric rail to the wood termination post. No wire stripping or special tools needed. Needs to be installed on a 6 to 8 inch wood termination/end, or gate post. For Hot Rail® fence systems only.

385459 White 385460 Black 385461 Brown



Sure-Hook® T-Bracket

Ideal for cross fence installations of 5" rail. For Centaur® and CenFlex® fence systems only.

385449 White 385450 Black 385451 Brown



Inside Corner Roller

The 5" rail glides along the roller reducing friction and providing smooth directional changes on inside corners. Needs to be installed on a 6 to 8 inch wood corner post.

385453 White **385454** Black



Sure-Hook® Splice Buckle

Splices two pieces of 5" rail together to create a longer piece of rail. No wire stripping or special tools needed. Quick and easy way to splice a 5" rail.

385446 White **385447** Black **385448** Brown



Termination Loop

Anchors the end of the 5" rail to the wood termination post. No wire stripping or special tools needed. This wrap-around anchor method is ideal for reducing the possibility of brace post twisting. Needs to be installed on a 6 to 8 inch wood termination/end, or gate post. **For Centaur® and CenFlex® fence systems only.**

346125 Termination Loop



STRAND Accessories

Centaur's Sure-Fit® Accessories are designed to provide a wide range of options when it comes to designing and installing your Centaur® fencing system. All components are produced to the highest quality standards, assuring you a fence installation that will stand the test of time.

SURE-FIT® ACCESSORIES

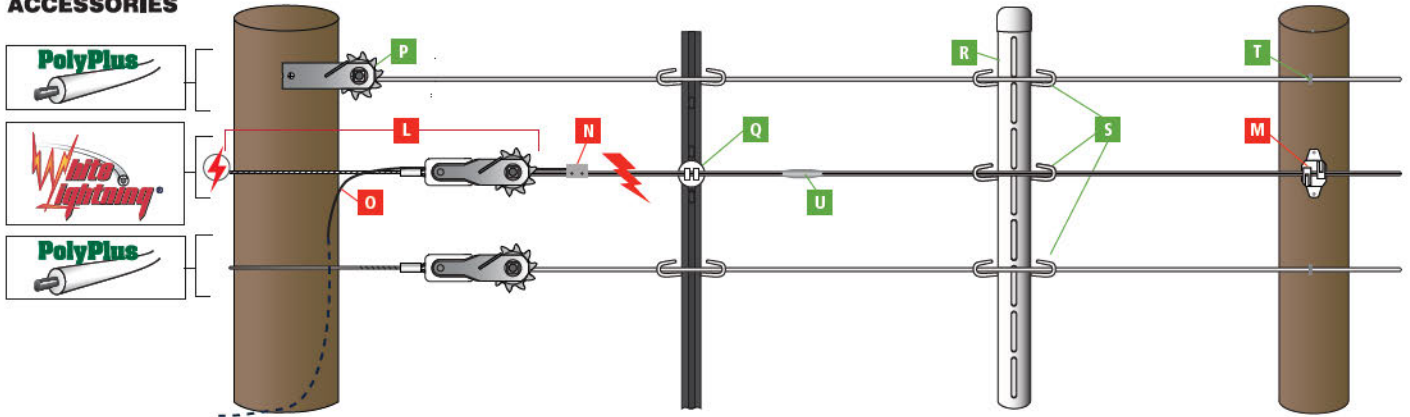

- | | | | |
|---|----------------------------|-------------------------------|------------------------|
| L Insulated Fencer's Lasso® | O Undergate Cable | R T-Post Safety Sleeve | T Barbed Staple |
| M Wood Post Insulator | P In-Line Tensioner | S T-Sleeve Clips | U Wire Link |
| N Snake Eyes® Electrical Connector | Q T-Post Insulators | | |

■ Non-electric fencing and accessories ■ Electric fencing and accessories



White Lightning® Electric Single Strand Fence Rolls
Electric safety coated high tensile steel wire. Three carbon veins for 360 degrees of shock. Polymer coated. 20-Year Limited Warranty

380006 White 1320' Roll **380008** Black 1320' Roll
380010 Brown 1320' Roll



PolyPlus Single Strand Fence Rolls
Safety coated high tensile steel wire. Polymer coated. 20-Year Limited Warranty

380038 White 1320' Roll **380034** Black 1320' Roll
380036 Brown 1320' Roll



T-Post Safety Sleeve with Cap
Completely covers standard metal T-Posts creating an attractive and safer fence post. No insulators required. T-Sleeve Clips not included.

385433 White (box of 25) **385434** Black (box of 25)

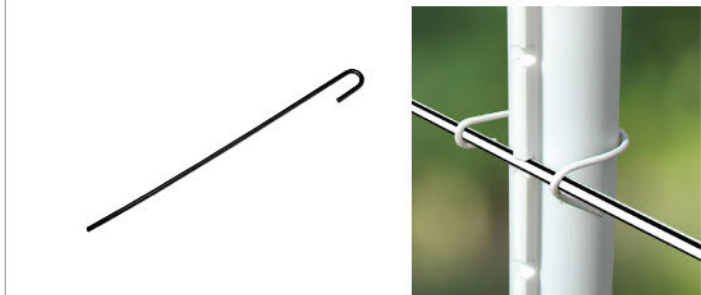

T-Sleeve Clips
Used to attach coated wire fence onto bare T-Post or T-Post Safety Sleeves. T-Post Safety Sleeve required when used to attach White Lightning® (electric) fence.

385259 White (pack of 50) **385260** Black (pack of 50)



Insulated Fencer's Lasso®

Insulated ratchet style tensioner with preattached cable and loop. Fast attachment to end/termination post. Adjusts easily with tensioner handle sold separately.

385160 Insulated Fencer's Lasso®



Wire Link

Securely splices coated wire together for a smooth connection. Strip off approximately 1.5 inches of wire coating and insert the bare wire into each end of the wire link.

385272 Wire Link for 12.5 gauge wire (pack of 3)



PolyPlus Quick End

Terminates coated wire at the end post. Strip 1 inch of coating from the wire, feed the wire through the Quick End, wrap around post, and insert wire into the spring-loaded end to lock into place. **Insultube required when used to attach White Lightning® (electric) fence.**

385462 White 385463 Black 385464 Brown



Insultube

Insulates electric fence wire around corners and end post terminations. Also can insulate electric wire when attached to wood line posts using Barbed Staples. **Caution, the Insultube must not become pierced during installation.**

385199 White (100' roll) 385201 Black (100' roll)



Wood Post Insulator

Attaches to wood line posts. Specially designed with a large opening to work with coated wire fence.

385231 White (pack of 25) 385133 Black (pack of 25)



T-Post Insulator

Attaches to standard metal T-Posts with no special tools needed. Specially designed with a large opening to work with coated wire fence.

385221 White (pack of 25) 385136 Black (pack of 25)

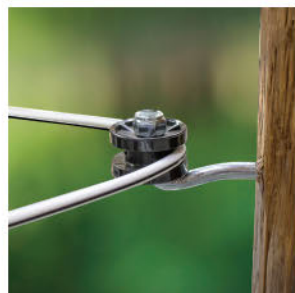

Lag Corner Insulator

Insulates and guides high tensile electric and non-electric fence wires along inside corner installations. Screws directly into the wooden corner posts.

385159 Lag Corner Insulator



In-Line Tensioner (ratchet style)

This tensioner mounts directly to the end/termination post. Easily adjusted with the Tensioner Handle. For PolyPlus (non-electric) wire fence only.

385369 In-Line Tensioner

INSTALLATION Tools & Hardware



5" and 3.5" Nails

Corrosion resistant ring shank nails help keep fence accessories secure.

385278 5" Nails, 1 lb. bag (21 pcs)

385280 3.5" Nails, 1 lb. (36 pcs) **385281** 3.5" Nails, 50 lb. box



2.5" Screws

Corrosion resistant screws help keep fence accessories secure.

385367 2.5" Screws, 1 lb. box (108 pcs)



1.75" Barbed Staples

Barbed for secure attachment. Length provides an eyelet style gap that permits room for adjustment when used to install strand fence on wood line posts. Galvanized to resist rust staining.

385296 Barbed Staples, 40 lb box

385297 Barbed Staples, 1 lb pack (52 pcs)



Diagonal Brace Plates

Specialized plates for securely connecting brace posts and corner posts. Install with galvanized 3.5" ring shank nails or 2.5" screws (not included).

385289 Diagonal Brace Plates (pack of 8)



Brace Pins

Heavy duty pins designed to connect brace posts and corner posts.

385171 Brace Pins 3/8" x 10" (bag of 25)



Tensioner Handle

The ultimate tool for Insulated Fencer's Lasso® and In-Line Ratchet-Style Tensioners. Self-ratcheting for quick and easy fence adjustments.

345121 Tensioner Handle



Spinning Jenny

Specially designed to help prevent fence kinks and tangles during installation. Essential tool for 5" rail or coated wire installation.

385120 Spinning Jenny

ELECTRIC Fence Accessories



Snake Eyes® Electrical Connector

Exclusive design for Hot Rail® and White Lightning® fence systems. Fast attachment and easy relocation. Two stinger channels for multiple links.

385387 Snake Eyes® (pack of 4)

385388 Snake Eyes® (pack of 12)



Insulator (ISO) Pad 7" x 4'

Insulates the Two-Way Barrel Tensioner when used with Hot Rail® electric 5" rail. A 7" x 12" section is required when installing the Two-Way Barrel Tensioner onto the wood line post.

385251 Insulator (ISO) Pad 7" x 4'



Undergate Cable 100'

Can carry power from energizer to fence or serve as an underground cable to route power under gated areas. Polymer coated to protect the wire against voltage leakage. Use continuous lengths only for installation, do not splice.

385360 Undergate Cable 100'



STAFIX® Fault Finder

Makes fence maintenance easy. The combined voltmeter and current meter is designed for the rapid location of electric fence faults.

385357 STAFIX® Fault Finder



STAFIX® Fence Alert™

Warning light begins flashing when fence voltage is too low (two preset voltage triggers can be selected). Visible up to .93 miles (1.5 km) away. No ground wires or external power sources required. Battery operated.

385355 STAFIX® Fence Alert™



Cut-Off Switch

Highly visible on/off position. Use to isolate sections of electric fence. Two stainless steel contacts for positive connection. Fits securely onto post.

385356
Cut-Off Switch



STAFIX® X1 Energizer

Powers up to 10 miles (40 acres). 1.0 J max. output energy (1.4 J stored energy). Features adjustable power/pulse speeds, versatile mounting options, day/night sensor, large terminals and indicator lights. Can be used in 110V, battery or solar power applications, providing convenient, versatile livestock control.

385353
STAFIX® X1 Energizer



STAFIX® X3 Energizer

Powers up to 30 miles (120 acres) 3.0 J max. output energy (4.5 J stored energy). Features low impedance, adjustable power/pulse speeds, versatile mounting options, day/night sensor, large terminals and indicator lights. Can be used in 110V, battery or solar power applications, providing convenient, versatile livestock control.

385354
STAFIX® X3 Energizer



TESTIMONIALS - Vet Tested and Approved

“

I absolutely love our Centaur fence. Not only does it still look good after over 15 years but it has actually saved at least 2 of our horse's lives and it even saved mine! A young stallion eager to get closer to the mares and had apparently tried to jump the fence and only made it half way. Suspended by the fence with back feet dangling, there he hung! No telling how long he had been dangling there. Who knows what the outcome would have been with wood fencing!

Another instance occurred with a blind rescue mare. Much to my dismay I saw the blind mare being chased "full speed ahead" by several other mares. She ran into the Centaur fence at a fast gallop, bounced off, slid under it down on her side and hung herself up. By the time I got to her she had freed herself and walked off. Not a scratch, not a limp! I can only imagine what a wooden fence or other would have caused.

Finally, Centaur saved my life too! With the front end loader I was moving an old wore out manure spreader back to the junk pile. As I slowly rounded a tight corner I lifted the spreader higher to clear the fence. As I did the tractor started over and I was soon to be a dead vet. Quickly hitting the clutch to my surprise it stopped rolling. The strong Centaur fence that I had lifted the spreader over caught the spreader allowing the tractor to correct and right itself. I said a prayer and cleaned my pants. Once again not only had Centaur saved the day. It had saved a life - mine! Wooden fencing would have only broken.

Dr. Dan Moore, D.V.M.
The Natural Vet



“

A three board oak fence took the life of "Chester" the beloved horse of Dr. Shelly Blenden, DVM. Chester was galloping along the fence line where "...there was slick clay mud and he was unable to stop". The impact of the collision caused the wood fence to spear Chester in the chest. When Shelly Blenden, DVM needed to purchase fence, she knew board fence was not an option. "I needed something that would keep my horses safe...I chose Centaur. I can feel safe... if he can't stop, Centaur will protect him."

Dr. Shelly Blenden, D.V.M.

TESTIMONIALS - What Our Customers are Saying

“

Our first consideration in choosing Centaur was safety. For the past two years our young stallions have put it through every test imaginable, and it has passed with flying colors.”

Carolyn
Ottawa, OH



“

I took a three year old stud colt in to train and had turned him out to pasture for a day off with another colt . He kicked uphill at the other horse and hung himself in the fence. I saw it happen from the house and by the time I got to him he had kicked free. He only had superficial skinned places and some hematoma in the following days... but it was not necessary to call the vet. I can only begin to imagine what it would have been like on any other type of fence. Experience tells me that I might have lost the horse and all that time I had put in on him... I have had this Centaur Fencing for more than 10 years now and am convinced it will outlive me.”

John M. Hutcheson
Gab Creek Farm: Foundation Morgans



“

We had a pony chase 8 heifers around the pasture... they all got scared and bunched up together and ran into the fence as a group at full speed. It was like a cartoon. They all bounced off in the opposite direction and kept going. The fence held and didn't even break the 4-inch posts. The fence paid for itself in that moment.”

C.K.
Adams, TN

“

We installed 12 miles of Centaur Fencing on our new farm in Saratoga-County, New York... and have spent less than six hours in the past 18 months on maintenance. Its greatest asset to our operation is the safety factor. Horses just do not get hurt when they come into contact with this fence.”

Blue Sky Farm
Saratoga-County, New York

“

We use the fencing for horses and were away for the week-end... When we returned, a storm had broken a tree and a huge limb was now resting on the fence... Once the tree and debris was removed, we were able to tighten the fence and it looked great! ...Thank you for a strong and durable product.”

Don and Carol Bartolet
Sun Spots Ranch
Dunnellon, Florida



“

The car wound up three feet inside the pasture, snapping off one fence post and pulling one out of the ground. The fencing held up well, stretching but not breaking and it actually stopped the car. When the car was removed, the fence was in place enough to contain the horses. It confirmed my faith that your fencing is the strongest, safest available.”

Burdett, NY

“

“We board, train and breed horses, primarily warmbloods, at our facility... We were impressed with the resilience, safety and appearance of this fencing material, having seen it at some of the top breeding farms on the east coast. Since the initial installation in 1991, we have not had one fence failure...mares charge others in the paddocks resulting in horses hitting the fence but they merely "bounce" off with no injury.

This is, bar none, the safest and best paddock material we have ever used. The almost 30-year old original fencing material is as sound as when I first installed it and still looks good. For the life of us, I cannot think why anyone would choose a different product for their paddocks or valuable livestock fencing.”

Patrick and Carolyn Adams
Yarra Yarra Ranch
Dublin, California



“

I was skeptical about this fence being able to hold up to our extreme winters here in the Upper Peninsula of Michigan but it has proved me wrong. It has withstood 40 below zero weather and still gave when pushed against... I'm amazed. Thank you for building such a safe and reliable fence! I have talked a lot of my fellow horse friends into Centaur. I think everyone should have it at their barns. I know it's all I'll ever use.”

Marquette, MI

“

We feel your fencing pays for itself every time the brakes fail on one of our youngsters or a foal puts a leg through a rail. Centaur has kept our seven horses injury free and given us peace of mind when we leave them.”

Pass Christian, MS

KleerFlex Door®

Clear Flexible Strip Doors Offer A Brilliant Solution To Doorways



Barns, Wash Racks, Sheds,
Rehabilitation Areas,
Feeders, Dog Houses,
Workshops & More

PROVIDING BRILLIANT SOLUTIONS TO DOORWAYS

Customized to fit your
needs and installation is
fast and easy.

- Keeps birds, insects and dust out
- Reduces hot and cold air loss
- Indoor and outdoor use
- Admits light
- Easy to install
- Smooth edges
- Available in various sizes



MaxBullet® Hardware System

The MaxBullet® aircraft aluminum hardware system features a unique bullet shaped locking feature for easy snap on/off strip replacement.

Once the hardware is installed, no tools are necessary for mounting the strips. Simply snap the strips on the MaxBullet® hardware and the job is complete.



Fence Layout How much spacing will between your line posts? 8' 10' 12'

Rail/Strand	Centaur® 5" Rail	Hot Rail® 5" Electric Rail	CenFlex® 5" Rail	PolyPlus	White Lightning®
Top					
2nd					
3rd					
4th					
5th					
6th					

• Type of post

____ Wood ____ T-Post
 *5" material cannot be installed on T-Post

Fence Layout Example:

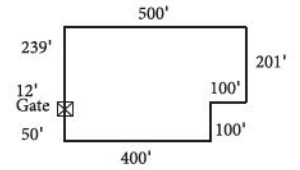

Draw the proposed fence in the space below.
 Mark any gates with an X.
 Note the distance of each of the lines you draw.

A large grid area for drawing the proposed fence layout. The grid is approximately 30 units wide and 40 units high.

Name: _____ Email: _____ Phone: _____



The Horse Friendly Fence[®]

2802 East Avalon Avenue | Muscle Shoals, AL 35661

Phone: 1-800-348-7787 | Fax: 1-866-455-1320 | Email: info@centaurhttp.com | Web: centaurhorsefence.com

